

UNEK44
AUSTRALIA
OFF ROAD ACCESSORIES

SKU: FR-S-R18-ASM0



Fitting Instructions

***Ford Ranger Raptor Dual Cab
Sliders***

***Australia's Best Off Road Products
Created... Not Cloned***

Contents

Why Uneek	3
Important Information	4
Components and part	5
Step 1: Prepare vehicle	6
Step 2: Prepare Sliders	7
Step 3: Fit Sliders	8
Step 4: Secure Sliders	9
Step 5: Pinning	9
Step 6: Finish	10
Finished Product	10

Why Uneek

Australian Designed and Built

All our products are designed and manufactured right here in Australia, allowing us to have better lead times and better quality control than companies manufacturing overseas. By supporting us you're supporting to grow the Australian economy and our brand.

Uneek Styling

We do not design our bars to look the same across the vehicle range. We fully develop our own product to individually suit each vehicle. We take time in designing from scratch and then test all our bars to comply with all relevant ADRs and Australian Standards.

Lightweight Through Smart Engineering

Having a steel bar doesn't mean you have to add more weight than is required to the front of your vehicle. Our engineering practises ensure we have the right protection, designed the right way to ensure protection is at its maximum and weights at its minimum.

Proven Off Road

We take our products out and test them right here in the heart of our country in our Australian conditions so we know our products can withstand anything you throw at them.

Increased Approach Angles

Our bars are designed to give you the best advantage while off road, with increased approach angles means you can tackle those tough and steep angles better than you could with the original setup or other alternatives.

Warranty





Uneek 4x4 back itself as Australia's leading steel bull bar manufacturer. This is why we provide you with the best steel bar warranty in Australia - 5 years.

Important Information



PLEASE READ BEFORE INSTALLATION.

- When installed in accordance with these instructions rock sliders do not affect the operation of the vehicles SRS airbags.
- This product must be installed exactly as per these instructions using only hardware supplied.
- Take a few moments to read instructions thoroughly before beginning work.
- In the event of damage to any bar component please contact Uneek 4x4 in regards to repair/replacement of components.
- Do not use this product for any vehicle make or model other than that specified on these instructions.
- Do not remove labels from this product.
- This product and its fixings must not be modified in any way unless stated in these fitting instructions.
- The installation of this product is recommended for trained personnel.
- These instructions are correct at time of publication. Uneek 4x4 cannot be held responsible for the impact of any changes subsequently made by the vehicle manufacturer.
- During installation it is the duty of the installer to check correct operation/clearances of all components.
- Installation time: 1 hour.
- Vehicle specific notes: A hydraulic jack will be required. Please note that the threads in the captive nut end plates are 1.5 pitch.

	EYE & EAR PROTECTION REQUIRED
	DRILLING REQUIRED
	TWO PERSON LIFT REQUIRED
	TORQUE SETTING
	CUTTING OR GRINDING REQUIRED

FASTENER TORQUE SETTINGS:

- M6 – 9Nm (4lb ft)
- M8 – 22Nm (16lb ft)
- M10 – 44Nm (32lb ft)
- M12 – 77Nm (57lb ft)

TOOLS REQUIRED:

Basic tool kit: Hydraulic jack, 'G' or 'F' clamp, drill and 10mm drill bit, sharp Stanley knife.

Components and part

MAIN PARTS

ITEM NO.	PART NUMBER	DESCRIPTION	Defa ult/QT Y.
1	03-0810	SLIDER REAR BRKT RAPTOR 18	1
2	03-0811	FORD RAPTOR 18 REAR BRACKET LH	1
3	03-803L	SLIDER MID BRKT RAPTOR 18	1
4	03-803R	SLIDER MID BRKT RAPTOR 18	1
5	09-0028	PANEL TREAD SLIDER HILUX 05	2
6	FR-S-R18-ASM1L	SLIDER WELDED ASSY RAPTOR 18 LH	1
7	FR-S-R18-ASM1R	SLIDER WELDED ASSY RAPTOR 18 RH	1

SMALL PARTS LIST

ITEM NO.	PART NUMBER	DESCRIPTION	Defa ult/QT Y.
8	HDPE SPACER-BLACK	HDPE SPACER - OD 20 X ID 8 X 6MM THICK BLACK	2
9	04-0113	PLATE NUT ASSY PX RANGER SLIDERS	6
10	05-0086	TUBE CRUSH PX RANGER SLIDER	4
11	M10FWX25	M10 FLAT WASHER X 25MM WIDE	18
12	M10SW	M10 SPRING WASHER	16
13	M10X1.5N	M10 X 1.5 NUT	2
14	M10X30	M10 X 1.5 X 30MM BOLT	10
15	M10X40X1.5	BOLT M10 X 40	6
16	M12 FW	M12 FLAT WASHER	4
17	M12 X 1.75 FN	M12 FLANGE NUT	4
18	M12X130X1.75	M12 X 130 X 1.75 BOLT	4
19	M6 FN	FLANGE NUT M6	16
20	M6X16 BHCS	M6 BUTTON HEAD CAP SCREW	16
21	JK-S-10	LOGO PLATE	2

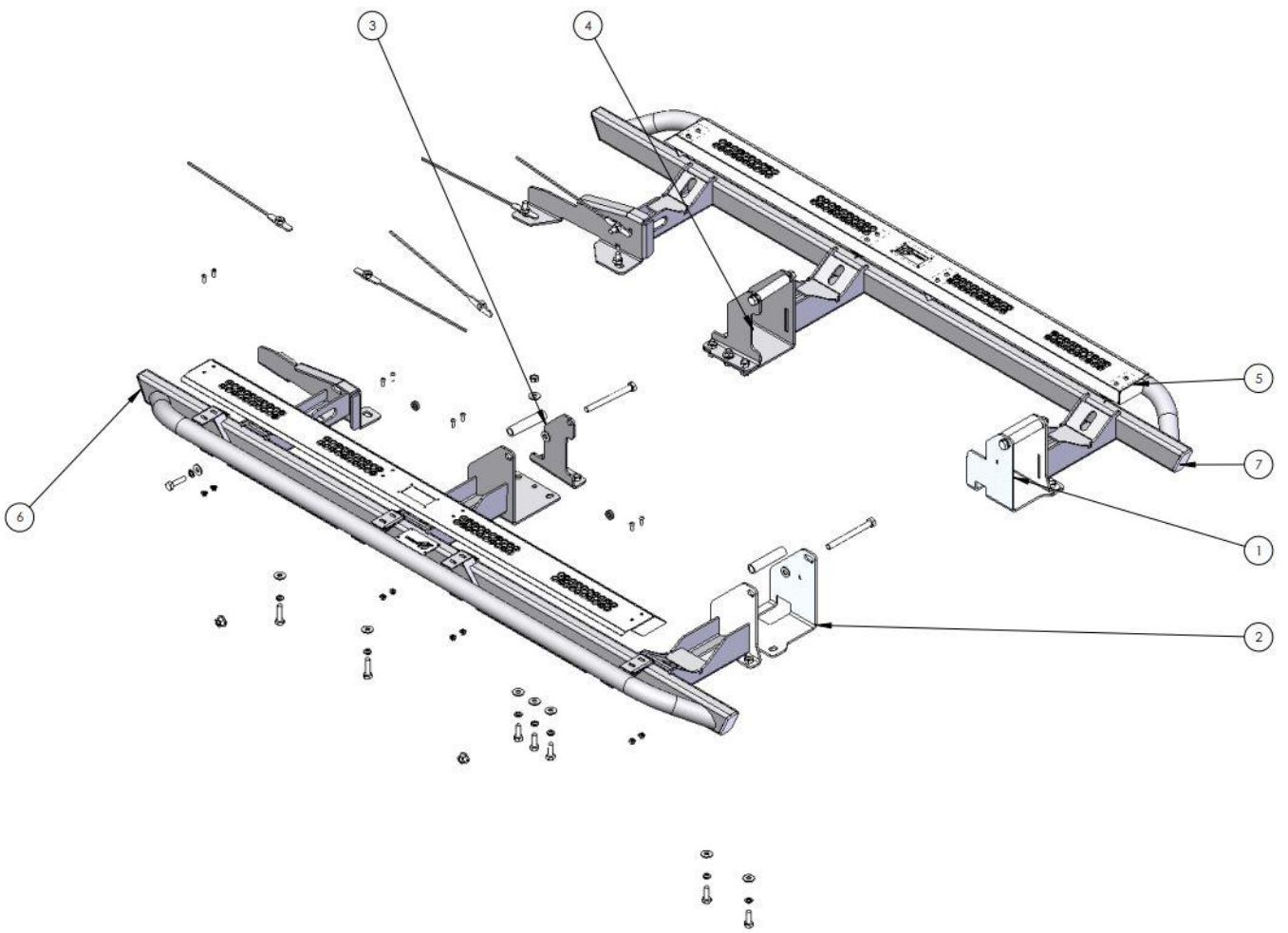

Step 1: Prepare vehicle

- Remove original side steps and brackets. Refit and tighten all bolts.
- Fit spacers between the passenger side chassis rail and both fuel line mounting brackets either side of the vehicle mid-point.

Note: Use T40 bit to unfasten brackets.

Tip: The upper bolts at the middle and rear sidestep brackets only need to be loosened enough to slide the steps out.



PART NUMBER	DESCRIPTION	FUEL LINE SPACER/QTY.
HDPE SPACER-BLACK	HDPE SPACER - OD 20 X ID 8 X 6MM THICK BLACK	2

Step 2: Prepare Sliders

Fit the tread plate sections to the sliders using M6 button head cap screws and M6 flange nuts.

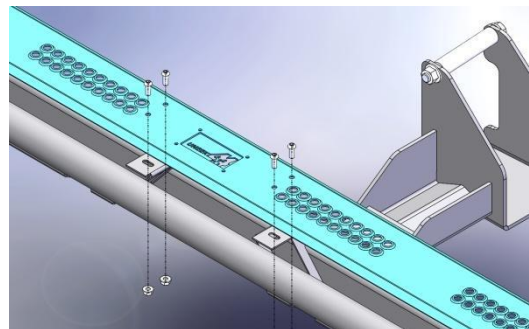

PART NUMBER	DESCRIPTION	STEP/QTY.
M6X16 BHCS	M6 BUTTON HEAD CAP SCREW	16
M6 FN	FLANGE NUT M6	16



M6-9Nm

Step 3: Fit Sliders

- Position the slider against the chassis rail and loosely fit the middle bracket.
- Loosely fit the rear bracket.

Tip: Fit the rear bracket on the passenger side last. To accommodate this, it may be necessary to trim the plastic guard away from the fuel tank. Use care when cutting.

Note: Assistance from another person and or hydraulic jack will be required to lift sliders into position.

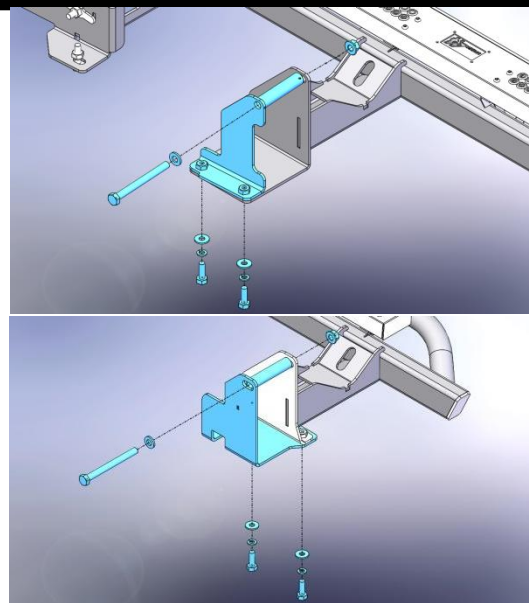

PART NUMBER	DESCRIPTION	REAR-MID MNT/QTY.
05-0086	TUBE CRUSH PX RANGER SLIDER	4
M12X130X1.75	M12 X 130 X 1.75 BOLT	4
M12 FW	M12 FLAT WASHER	4
M10X30	M10 X 1.5 X 30MM BOLT	8
M10FWX25	M10 FLAT WASHER X 25MM WIDE	8
M10SW	M10 SPRING WASHER	8
M12 X 1.75 FN	M12 FLANGE NUT	4

Caution: Ensure adequate clearance between all mountings and hardware and vehicle fuel and brake lines

Step 4: Secure Sliders

- Align mount holes in front bracket to the corresponding holes in the chassis.
- Fit internal nut plates into chassis, bending plate arms as needed and secure.
- Align sliders to vehicle sills and secure all fasteners.

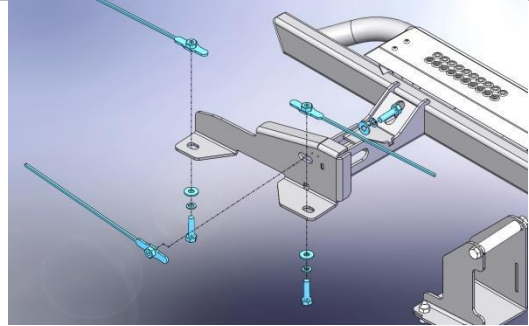

PART NUMBER	DESCRIPTION	FRONT MNT/QTY.
04-0113	PLATE NUT ASSY PX RANGER SLIDERS	6
M10FWX25	M10 FLAT WASHER X 25MM WIDE	6
M10SW	M10 SPRING WASHER	6
M10X40X1.5	BOLT M10 X 40	6

Tip: A large F clamp or G clamp is useful to hold inner mounts hard up against chassis rails whilst aligning the slider.



M10-44Nm, M12-77Nm

Step 5: Pinning

Drill through 10mm centre hole on middle mounting brackets. Secure using M10 Hardware.



PART NUMBER	DESCRIPTION	PINNING BOLTS/QTY.
M10X30	M10 X 1.5 X 30MM BOLT	2
M10FWX25	M10 FLAT WASHER X 25MM WIDE	4
M10X1.5N	M10 X 1.5 NUT	2
M10SW	M10 SPRING WASHER	2



M10-44Nm

Step 6: Finish

Step back and admire your work. Awesome job!

Finished Product



Revised: 17/01/2020

***Australias Best
Off Road Products
Created... Not Cloned***

20 Gateway Drive, Carrum Downs, VIC, 3201

1800 806 952

www.uneek4x4.com.au

