

UNEK44
AUSTRALIA
OFF ROAD ACCESSORIES

SKU: JG-HL-B-ASM0



Fitting Instructions

Jeep JK Wrangler

Bonnet High Lift Jack Brackets

***Australia's Best Off Road Products
Created... Not Cloned***

Contents

WHY UNEEK	3
IMPORTANT INFORMATION	4
COMPONENTS AND PARTS	5
STEP 1	6
STEP 2	6
STEP 3	6
STEP 4	6
FINISHED PRODUCT	7

Why Uneek

Australian Designed and Built

All our products are designed and manufactured right here in Australia, allowing us to have better lead times and better quality control than companies manufacturing overseas. By supporting us you're supporting to grow the Australian economy and our brand.

Uneek Styling

We do not design our bars to look the same across the vehicle range. We fully develop our own product to individually suit each vehicle. We take time in designing from scratch and then test all our bars to comply with all relevant ADRs and Australian Standards.

Lightweight Through Smart Engineering

Having a steel bar doesn't mean you have to add more weight than is required to the front of your vehicle. Our engineering practises ensure we have the right protection, designed the right way to ensure protection is at its maximum and weights at its minimum.

Proven Off Road

We take our products out and test them right here in the heart of our country in our Australian conditions so we know our products can withstand anything you throw at them.

Increased Approach Angles

Our bars are designed to give you the best advantage while off road, with increased approach angles means you can tackle those tough and steep angles better than you could with the original setup or other alternatives.

Warranty

Uneek 4x4 back itself as Australia's leading steel bull bar manufacturer. This is why we provide you with the best steel bar warranty in Australia - 5 years.

Important Information



PLEASE READ BEFORE INSTALLATION.

- These instructions detail how to fit your new high lift jack brackets to your jeep bonnet. These brackets suit a TJ or JK wrangler. Our design intent is to remove your jack from the back of your jeep where it can turn into a dangerous missile during heavy 4wd driving or an accident, while putting it in an easy to access point for when it's needed for the 101 uses you can find for a high lift jack.
- Install time is roughly 20min
- It is recommended you only leave your high lift jack on the bonnet ("hood" if you're a yank) when going Offroad and remove it during day to day driving. This will not only save fuel when carrying a heavy jack but will reduce the chance of the extra damage from the heavy jack during an accident.
- These brackets utilize the existing mounting holes and captive nuts for the bonnet hinges and require no drilling or bracing.
- The spacers are for JK drivers only.



EYE & EAR PROTECTION REQUIRED



DRILLING REQUIRED



TWO PERSON LIFT REQUIRED



TORQUE SETTING



CUTTING OR GRINDING REQUIRED

FASTENER TORQUE SETTINGS:

M6 – 9Nm (4lb ft)

M8 – 22Nm (16lb ft)

M10 – 44Nm (32lb ft)

M12 – 77Nm (57lb ft)

TOOLS REQUIRED:

Torque drivers, hand spanners, 10mm Allen key.

Components and parts

Item No.	Part Number	Description	Qty
1	JG-HL-B-ASM1	Bonnet mount Brkt (1 x LH, 1 x RH)	2
2	M12x40 SS cap screw	M12x40 BUTTON HEAD cap screw	2
3	M12 HDFW	M12 Heavy Duty Washer, Zinc	2
4	M12 SW	M12 Spring Washer Zinc	2
5	5/16 x1 Bolt	5/16 UNC x 1" Bolt Zinc	6
6	M8 FW	M8 Flat Washer Zinc	6
7	M8 x 30	M8 X 30 HEX BOLTS	4

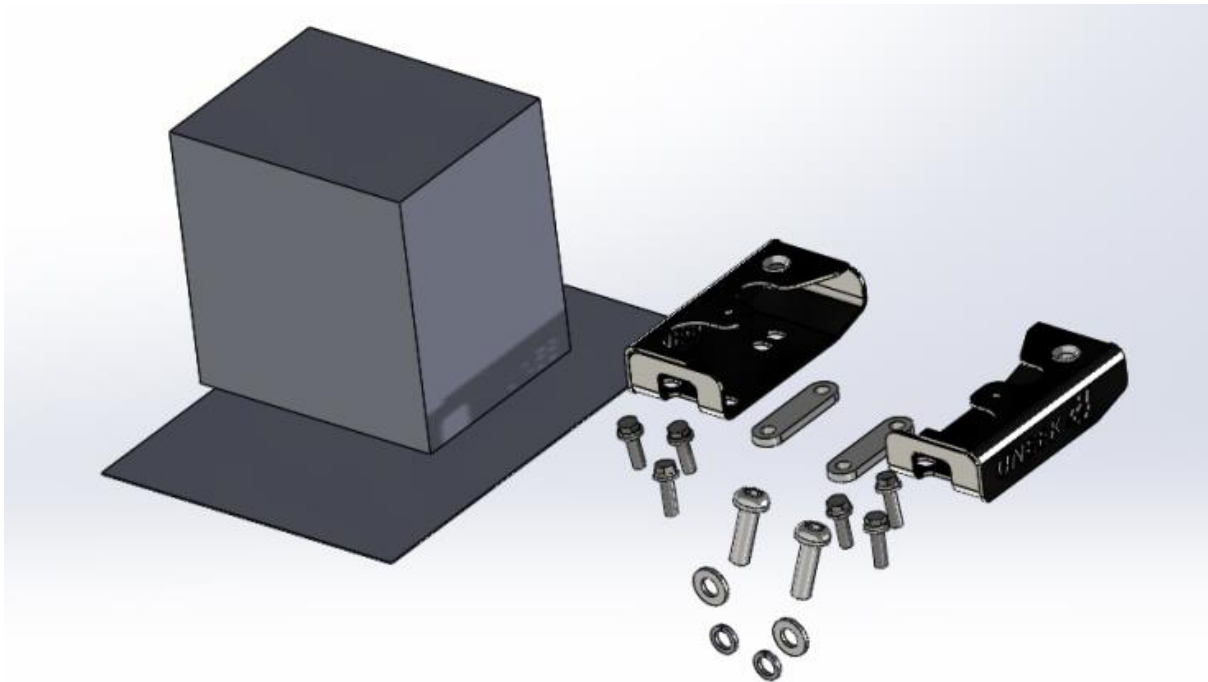

Step 1

Remove Torque bolts on bonnet hinge

x 2 for JK

x 3 for TJ

These bolts can be very stiff, take care in undoing them.



Step 2

Loosely fit bonnet bracket on top of bonnet.

For TJ wranglers use 5/16" bolts x 3.

For JK wranglers use spacer under the bracket then fit 2 x M8 bolts per bonnet bracket.

Repeat for other side.



Step 3

Plate jack on of brackets in desired position.

You may need to move the bonnet brackets side to side to allow the M12 bolts to line up with the jack.

Once you can freely screw in the M12 bolts through the jack, torque down the bonnet mounts bolts underneath.

Repeat for other side.



Step 4

Ensure you have an isolator on high lift jack that keeps handle secured to steam, cable ties will also work.



Finished Product



Revised: 27/08/2019

***Australia's Best
Off Road Products
Created... Not Cloned***

20 Gateway Drive, Carrum Downs, VIC, 3201

1800 806 952

www.uneek4x4.com.au

