

UNEK44
AUSTRALIA
OFF ROAD ACCESSORIES

SKU: JK-D44-RT-ASM0



Fitting Instructions

***Jeep JK Wrangler 2007 on
JK D44 Bolt on Rear Diff Truss***

***Australia's Best Off Road Products
Created... Not Cloned***

Contents

WHY UNEEK	3
IMPORTANT INFORMATION	4
COMPONENTS AND PARTS	5
STEP 1	6
STEP 2	6
STEP 3	6
STEP 4	6
STEP 5	7
STEP 6	7
STEP 7	7
FINISHED PRODUCT	8

Why Uneek

Australian Designed and Built

All our products are designed and manufactured right here in Australia, allowing us to have better lead times and better quality control than companies manufacturing overseas. By supporting us you're supporting to grow the Australian economy and our brand.

Uneek Styling

We do not design our bars to look the same across the vehicle range. We fully develop our own product to individually suit each vehicle. We take time in designing from scratch and then test all our bars to comply with all relevant ADRs and Australian Standards.

Lightweight Through Smart Engineering

Having a steel bar doesn't mean you have to add more weight than is required to the front of your vehicle. Our engineering practises ensure we have the right protection, designed the right way to ensure protection is at its maximum and weights at its minimum.

Proven Off Road

We take our products out and test them right here in the heart of our country in our Australian conditions so we know our products can withstand anything you throw at them.

Increased Approach Angles

Our bars are designed to give you the best advantage while off road, with increased approach angles means you can tackle those tough and steep angles better than you could with the original setup or other alternatives.

Warranty

Uneek 4x4 back itself as Australia's leading steel bull bar manufacturer. This is why we provide you with the best steel bar warranty in Australia - 5 years.

Important Information



PLEASE READ BEFORE INSTALLATION.

- This product must be installed exactly as per these instructions using only hardware supplied.
- This product or its fixings must not be modified in any way.
- These instructions are correct as at the publication date. Uneek 4x4 Pty Ltd cannot be held responsible for the impact of any changes subsequently made by the vehicle manufacturer.
- During installation, it is the duty of the installer to check correct operation/clearances of all components.
- Installation time is estimated at 15 min.



EYE & EAR PROTECTION REQUIRED



DRILLING REQUIRED



TWO PERSON LIFT REQUIRED



TORQUE SETTING



CUTTING OR GRINDING REQUIRED

FASTENER TORQUE SETTINGS:

M6 – 9Nm (4lb ft)

M8 – 22Nm (16lb ft)

M10 – 44Nm (32lb ft)

M12 – 77Nm (57lb ft)

TOOLS REQUIRED:

Hand spanners or socket set.

Components and parts

	Part No	Description	Qty
1	JK-D44-RT-ASM1	D44 Jk bolt on rear diff truss weldment	1
2	E16-76	EzyStrut brace 76mm	4
3	M12 x 50 x 1.5 HT ZP	M12 x 50 x 1.5 bolts	8
4	M12 NYLOC	M12 Nyloc nuts	8
5	Pinch Weld 100mm	100mm of pinch weld or conduit	1

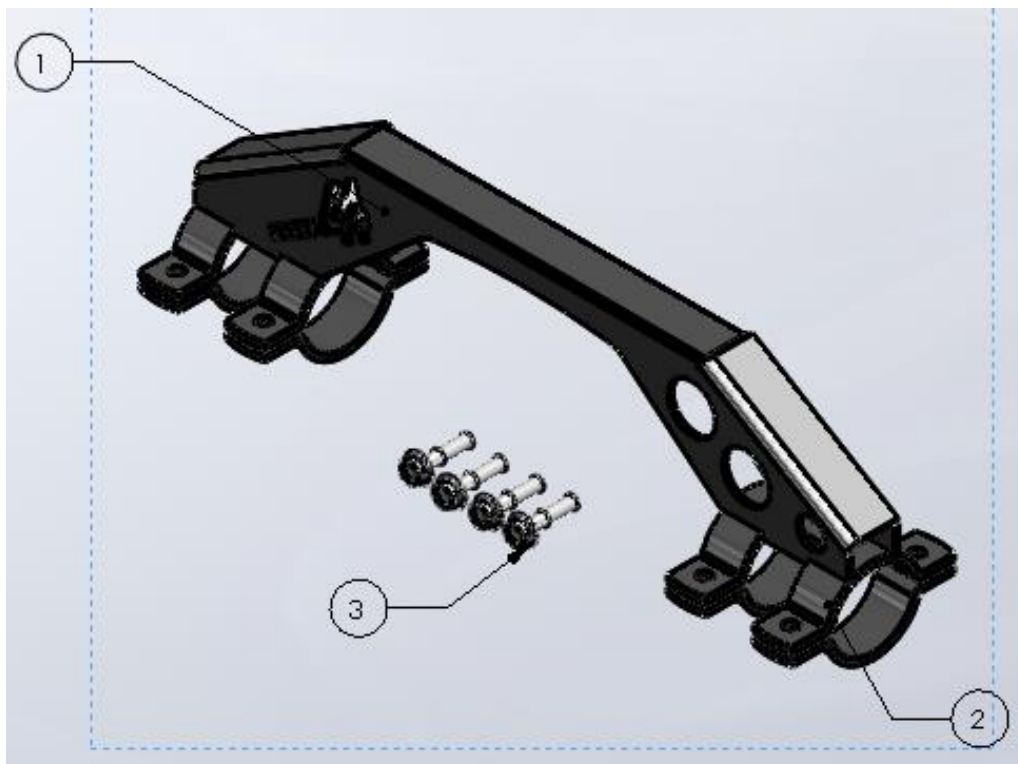

Step 1

Unpack and make sure all items are accounted for as per contents above.



Step 2

Simply pull the breather tube off the diff housing.



Step 3

With the Uneek Logo facing you on your left-hand side, line the second hole from the right with the pinch weld or conduit.

This is to prevent any tearing or ripping of the breather while your diff goes up and down.



Step 4

Lift the diff truss up over the diff and sit it on top of the diff with the Uneek logo on the passenger side (LHS.) Insert the breather tube through the protected hole and fit it back on its barb.



Step 5

Offer up each lower clamp to the welded upper clamps and hand tighten each bolt.



Step 6

Tension up each bolt evenly taking your time to go to opposite ends to ensure you don't over tighten one side.

There should be a 15-25mm gap between the upper and lower clamps.

After travelling 500km, crawl under your Jeep to ensure the bolts have not worked loose.



Step 7

You're done. Easy wasn't it?

Now go enjoy piece of mind that your diff is now 56% more rigid.

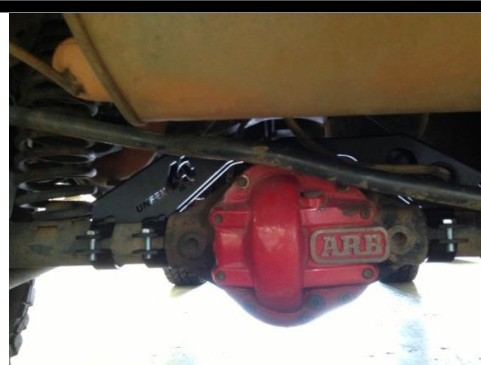

Finished Product



Revised: 27/08/2019

***Australia's Best
Off Road Products
Created... Not Cloned***

20 Gateway Drive, Carrum Downs, VIC, 3201

1800 806 952

www.uneek4x4.com.au

