

UNEK44
AUSTRALIA
OFF ROAD ACCESSORIES

SKU: JK-FB-T-ASM5/ASM5ARB



Fitting Instructions
Jeep JK Wrangler 2007+
Skid Plate

Australia's Best Off Road Products
Created... Not Cloned

Contents

WHY UNEEK	3
IMPORTANT INFORMATION	4
COMPONENTS AND PARTS	5
STEP 1	6
STEP 2	6
STEP 3	6
STEP 4	6
FINISHED PRODUCT	7

Why Uneek

Australian Designed and Built

All our products are designed and manufactured right here in Australia, allowing us to have better lead times and better quality control than companies manufacturing overseas. By supporting us you're supporting to grow the Australian economy and our brand.

Uneek Styling

We do not design our bars to look the same across the vehicle range. We fully develop our own product to individually suit each vehicle. We take time in designing from scratch and then test all our bars to comply with all relevant ADRs and Australian Standards.

Lightweight Through Smart Engineering

Having a steel bar doesn't mean you have to add more weight than is required to the front of your vehicle. Our engineering practises ensure we have the right protection, designed the right way to ensure protection is at its maximum and weights at its minimum.

Proven Off Road

We take our products out and test them right here in the heart of our country in our Australian conditions so we know our products can withstand anything you throw at them.

Increased Approach Angles

Our bars are designed to give you the best advantage while off road, with increased approach angles means you can tackle those tough and steep angles better than you could with the original setup or other alternatives.

Warranty

Uneek 4x4 back itself as Australia's leading steel bull bar manufacturer. This is why we provide you with the best steel bar warranty in Australia - 5 years.

Important Information



PLEASE READ BEFORE INSTALLATION.

- When installed in accordance with these instructions, the front protection bar does not affect operation of the SRS airbag.
- In the event of damage to any component, contact Uneek 4x4 Pty Ltd for options.
- Do not use this product for any vehicle make or model, other than specified on these instructions.
- These instructions are correct as at the publication date. Uneek 4x4 Pty Ltd cannot be held responsible for the impact of any changes subsequently made by the vehicle manufacturer or ARB if fitting to and ARB bull bar.
- During installation, it is the duty of the installer to check correct operation/ clearances of all components.
- Installation time is estimated at 15min for Uneek bull bar owners and 1 hour for ARB bull bar owners.

FASTENER TORQUE SETTINGS:

M6 – 9Nm (4lb ft)

M8 – 22Nm (16lb ft)

M10 – 44Nm (32lb ft)

M12 – 77Nm (57lb ft)

Tool Required:

Hand Spanners or Socket set

Allen Keys

If fitting to ARB bull bar the following will also be required:

Power Drill

Centre punch

9mm drill bit

Components and parts

ITEM NO.	PART NUMBER	DESCRIPTION	NO ROCK LIGHTS/QTY.
1	JK-FB-T-40	JK bash plate	1
2	JK-FB-T-41L	Bash plate gusset	1
3	JK-FB-T-41R	Bash plate gusset	1
4	04-0086	ASSY M10 ROOT NUT PLATE	2
5	M10X30	M10 X 1.5 X 30MM BOLT	2
6	M10SW	M10 SPRING WASHER	2
7	M10 FLAT WASHER X 25	M10 FLAT WASHER	2
8	M8X25 BHCS	M8X25 BUTTON HEAD CAP SCREW	6
9	M8 FLANGE NUT	M8 FLANGE NUT	6
10	M8 FW X 22	FLAT WASHER 8MM LARGE	6

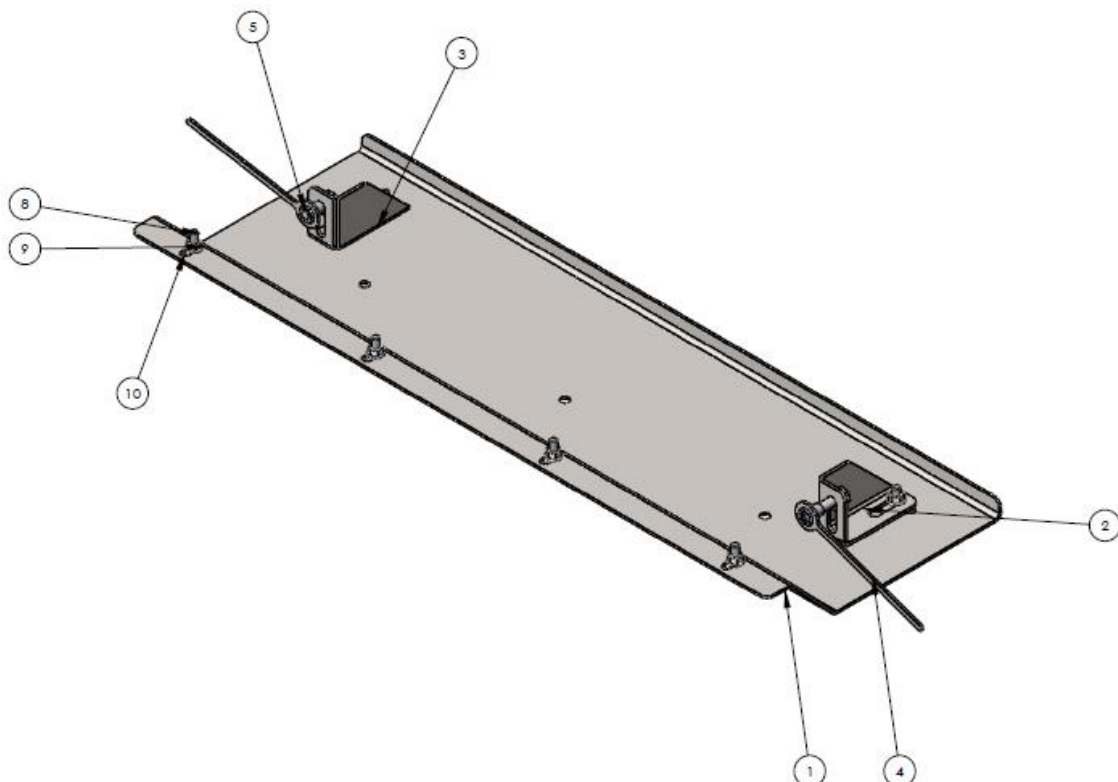

Step 1

Loosely fit bash plate gusset with nut plates on vehicle cross member.



Step 2

For Uneek bull bar: Hold the skid plate up to the bull bar and with M8 fasteners feed through the bull bar and the forward slotted holes on the skid plate, then the rear most slots into bash plate gussets.

Once all are lined up, torque up and you're done.

ARB bull bar owners proceed to step 3.



Step 3

For ARB bull bar: Fit the rear most bolts then hold the skid plate up to the bull bar. Mark a dot in the centre of all the slots. Remove skid plate, centre punch holes then drill out to 9mm, and then proceed to fit skid plate with M8 hardware.

Torque up and you're done.



Step 4

If fitting optional rock lights, bolt them into skid plate.

We suggest running the wires for these and splicing into your fog light wires so they operate with the fog lights.



Finished Product



Revised: 25/07/2019

***Australia's Best
Off Road Products
Created... Not Cloned***

20 Gateway Drive, Carrum Downs, VIC, 3201

1800 806 952

www.uneek4x4.com.au

