

**UNEEK** **4x4**  
A U S T R A L I A  
OFF ROAD ACCESSORIES

**SKU: JK-TD-FR-ASM0**



***Fitting Instructions***

***Jeep JK Wrangler***

***Tube Door Front***

***Australia's Best Off Road Products  
Created... Not Cloned***

# **Contents**

---

<b>WHY UNEEK</b>	<b>3</b>
<b>IMPORTANT INFORMATION</b>	<b>4</b>
<b>COMPONENTS AND PARTS</b>	<b>5</b>
<b>STEP 1</b>	<b>6</b>
<b>STEP 2</b>	<b>6</b>
<b>STEP 3</b>	<b>6</b>
<b>STEP 4</b>	<b>6</b>
<b>STEP 5</b>	<b>7</b>
<b>STEP 6</b>	<b>7</b>
<b>FINISHED PRODUCT</b>	<b>8</b>

# ***Why Uneek***

---

## ***Australian Designed and Built***

All our products are designed and manufactured right here in Australia, allowing us to have better lead times and better quality control than companies manufacturing overseas. By supporting us you're supporting to grow the Australian economy and our brand.

## ***Uneek Styling***

We do not design our bars to look the same across the vehicle range. We fully develop our own product to individually suit each vehicle. We take time in designing from scratch and then test all our bars to comply with all relevant ADRs and Australian Standards.

## ***Lightweight Through Smart Engineering***

Having a steel bar doesn't mean you have to add more weight than is required to the front of your vehicle. Our engineering practises ensure we have the right protection, designed the right way to ensure protection is at its maximum and weights at its minimum.

## ***Proven Off Road***

We take our products out and test them right here in the heart of our country in our Australian conditions so we know our products can withstand anything you throw at them.

## ***Increased Approach Angles***

Our bars are designed to give you the best advantage while off road, with increased approach angles means you can tackle those tough and steep angles better than you could with the original setup or other alternatives.

## ***Warranty***

Uneek 4x4 back itself as Australia's leading steel bull bar manufacturer. This is why we provide you with the best steel bar warranty in Australia - 5 years.

# Important Information

---



**PLEASE READ BEFORE INSTALLATION.**

- Take a few moments to read instructions thoroughly before beginning work.
- In the event of damage to any component please contact Uneek 4x4 in regards to repair/replacement of components.
- These instructions are correct at time of publication. Uneek 4x4 cannot be held responsible for the impact of any changes subsequently made by the vehicle manufacturer.
- During installation it is the duty of the installer to check correct operation/clearances of all components.
- Check local laws regarding legality when running these doors.
- Never run with these doors without having both side mirrors attached.
- Installation time: 30 MIN



**EYE & EAR PROTECTION REQUIRED**



**DRILLING REQUIRED**



**TWO PERSON LIFT REQUIRED**



**TORQUE SETTING**



**CUTTING OR GRINDING REQUIRED**

---

## FASTENER TORQUE SETTINGS:

M6 – 9Nm (4lb ft)

M8 – 22Nm (16lb ft)

M10 – 44Nm (32lb ft)

M12 – 77Nm (57lb ft)

## TOOLS REQUIRED:

Basic tool kit, hex keys, hammer and torque driver.

# Components and parts

ITEM NO.	PART NUMBER	DESCRIPTION	QTY.
1	JK-TD-ASM1R	JK TUBE DOOR RH FR	1
2	JK-TD-ASM1L	JK TUBE DOOR LH FR	1
3	Shipper 950 x 550 x 160	Shipper 950 x 550 x 160	1
4	LATCH RH	LATCH RH	1
5	JK-TD-11	MIRROR SPACER	2
6	U4X4-LOGO PLATE-1	LOGO PLATE-1	3
7	LATCH LH	door latch lh	1
8	m6 washer	m6 washer	16
9	M6 FN	FLANGE NUT M6	8
10	M6X25 BHCS	M6X25 BUTTON HEAD CAP SCREW S/S	8

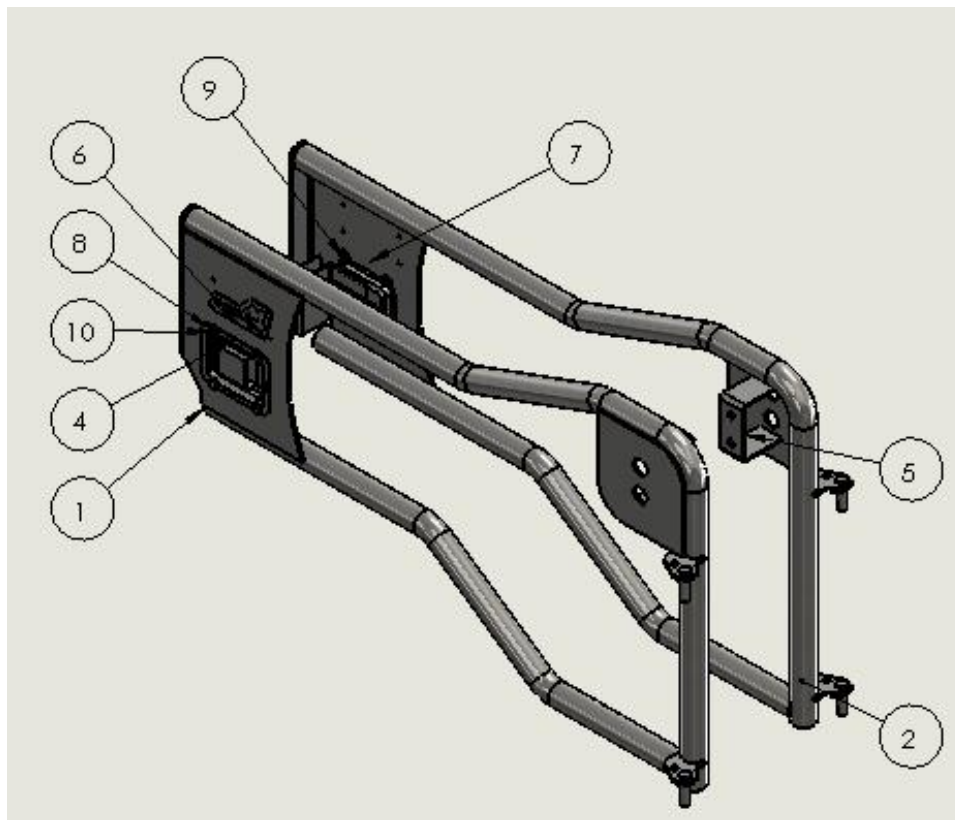

## Step 1

Remove your factory doors by undoing Torx nuts on the bottom of both door hinges. Unplug wiring loom and lift door off hinges.



## Step 2

Fit door latches with supplied hardware. Latch opening should always be on the lower side of the door.



## Step 3

This picture shows the left-hand door with the latch in the correct orientation.



## Step 4

Lift the tube door on to the jeeps door hinges and push down till the top of the winch barrel meets the tube door hinge plate (flat section pin is welded to.) You may need to straighten each pin as they can distort during welding, powder coating and even shipping. Do this by tapping the pin straight with a hammer or mallet.

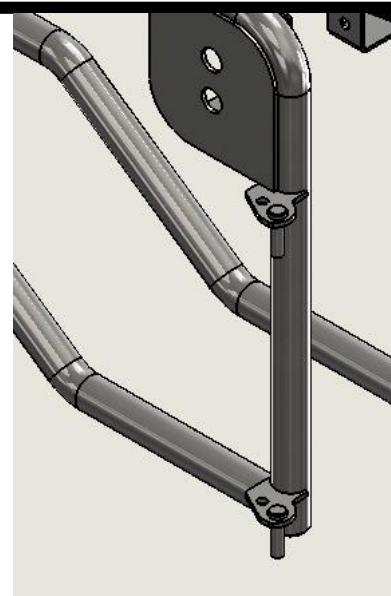

## Step 5

Closing the door often requires more force than the original door. Adjust the latch as required.

Now is a good time to fit the optional mesh inserts if purchased. Simply wrap around each door and secure with attached Velcro straps.



## Step 6

If relocating the factory mirrors, use supplied mirror mounts as a spacer for the factory mirrors. Bolt up using factory hardware. Otherwise use the hole supplied near the hinge pin to mount Olympic safari mirrors.

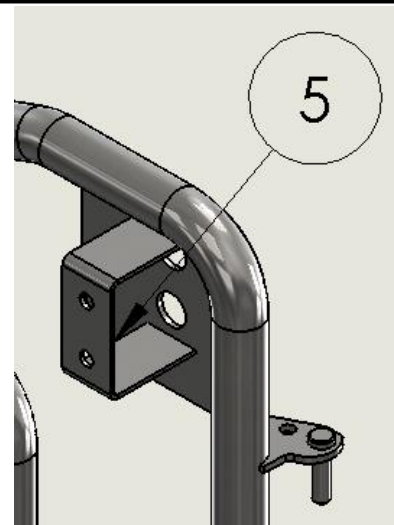

# ***Finished Product***

---





Revised: 27/08/2019

***Australia's Best  
Off Road Products  
Created... Not Cloned***

20 Gateway Drive, Carrum Downs, VIC, 3201

1800 806 952

[www.uneek4x4.com.au](http://www.uneek4x4.com.au)

