

UNEK44
AUSTRALIA
OFF ROAD ACCESSORIES

SKU: JK-RB-ASM10



Fitting Instructions

Jeep JK Wrangler 2007 on Number Plate Relocation Bracket

***Australia's Best Off Road Products
Created... Not Cloned***

Contents

WHY UNEEK	3
IMPORTANT INFORMATION	4
COMPONENTS AND PARTS	5
STEP 1	6
STEP 2	6
STEP 3	6
STEP 4	6
FINISHED PRODUCT	7

Why Uneek

Australian Designed and Built

All our products are designed and manufactured right here in Australia, allowing us to have better lead times and better quality control than companies manufacturing overseas. By supporting us you're supporting to grow the Australian economy and our brand.

Uneek Styling

We do not design our bars to look the same across the vehicle range. We fully develop our own product to individually suit each vehicle. We take time in designing from scratch and then test all our bars to comply with all relevant ADRs and Australian Standards.

Lightweight Through Smart Engineering

Having a steel bar doesn't mean you have to add more weight than is required to the front of your vehicle. Our engineering practises ensure we have the right protection, designed the right way to ensure protection is at its maximum and weights at its minimum.

Proven Off Road

We take our products out and test them right here in the heart of our country in our Australian conditions so we know our products can withstand anything you throw at them.

Increased Approach Angles

Our bars are designed to give you the best advantage while off road, with increased approach angles means you can tackle those tough and steep angles better than you could with the original setup or other alternatives.

Warranty

Uneek 4x4 back itself as Australia's leading steel bull bar manufacturer. This is why we provide you with the best steel bar warranty in Australia - 5 years.

Important Information



PLEASE READ BEFORE INSTALLATION.

- This kit allows you to relocate your number plate up on to the spare tyre when fitting aftermarket bumpers to your JK wrangler.
- You will be required to run the original wires from your number plate to the new bracket to ensure the lamp works.
- A working rear number plate lamp is a roadworthy item.
- These instructions are correct as at the publication date. Uneek 4x4 Pty Ltd cannot be held responsible for the impact of any changes subsequently made by the vehicle manufacturer.
- During installation, it is the duty of the installer to check correct operation/ clearances of all components.
- Installation time is estimated at 1 hour.



EYE & EAR PROTECTION REQUIRED



DRILLING REQUIRED



TWO PERSON LIFT REQUIRED



TORQUE SETTING



CUTTING OR GRINDING REQUIRED

FASTENER TORQUE SETTINGS:

M6 – 9Nm (4lb ft)

M8 – 22Nm (16lb ft)

M10 – 44Nm (32lb ft)

M12 – 77Nm (57lb ft)

TOOLS REQUIRED:

13mm socket and drive or spanner, electrical connectors for new number plate light.

Components and parts

ITEM NO.	PART NUMBER	Description	QTY.
1	JK-RB-ASM7	NUMBER PLATE MOUNT	1
2	JK-RB-ASM6	NUMBER PLATE MOUNT	1
3	BR25B	LED NUMBER PLATE LIGHT	1
4	M6 NYLOCK NUT	M6 NYLOCK NUT	2
5	M6 x 30 HEX BOLT Z/P	M6 X 30 HEX BOLT Z/P	2
6	M8 WASHER	M8 WASHER	1
7	M8 SPRING WASHER	M8 SPRING WASHER	1
8	M8 X 30	M8 X 30 HEX BOLT 8.8 Z/P	1
9	ALSTOM NUT M8	ALSTOM M8 NUT	1
10	SL7	380 X 280 X 230	1

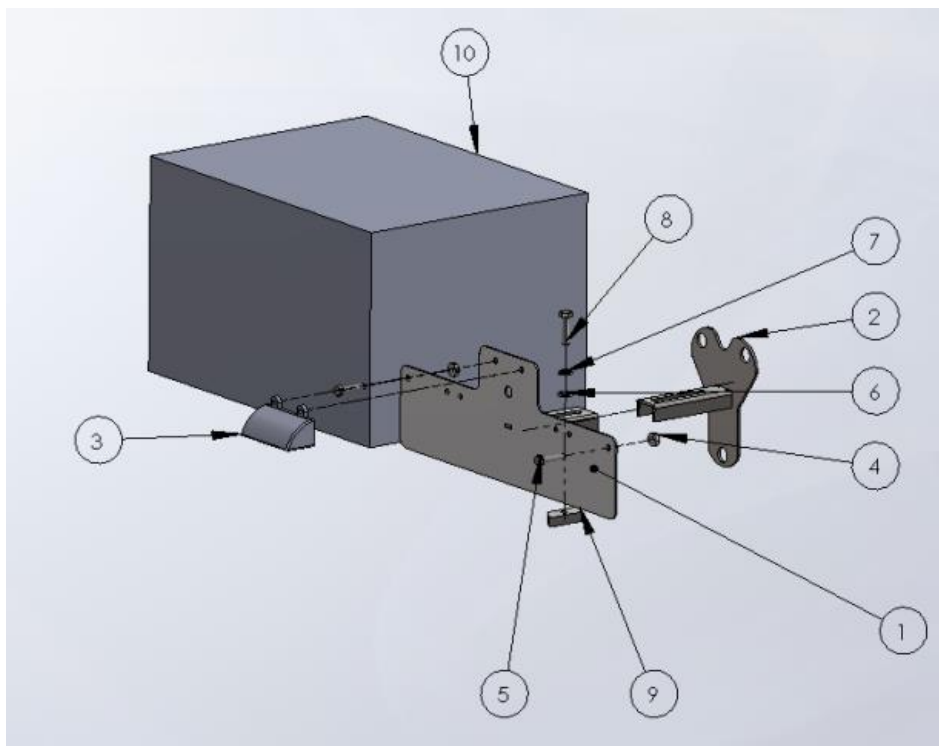

Step 1

Remove spare tyre and knock out centre cap from centre of rim.

Step 2

Place backing plate of number plate relocation on factory tyre carrier.

Fit tyre on to tyre carrier and torque up wheel nuts.



Step 3

Fit outer plate of number plate relocation with supplied nut plate and M8 bolt and washer.



Step 4

Run the original number plate wires up to the new wires of the relocation bracket. Use a quick connect fitting found at any auto parts shop so you can easily remove the spare tyre later without messing with electrical tools.

Don't forget to refit your number plate now.



Finished Product



Revised: 27/08/2019

***Australia's Best
Off Road Products
Created... Not Cloned***

20 Gateway Drive, Carrum Downs, VIC, 3201

1800 806 952

www.uneek4x4.com.au

