

**UNEK44**  
AUSTRALIA  
OFF ROAD ACCESSORIES

**SKU: NN-FB-NPCE-ASM0**



## ***Fitting Instructions***

***Nissan Navara NP300 2015on***

***Commander Bull Bar***

***Australia's Best Off Road Products  
Created... Not Cloned***

# **Contents**

---

<b>WHY UNEEK</b>	<b>3</b>
<b>IMPORTANT INFORMATION</b>	<b>4</b>
<b>COMPONENTS AND PARTS</b>	<b>5</b>
<b>COMPONENTS AND PARTS</b>	<b>6</b>
<b>STEP 1</b>	<b>7</b>
<b>STEP 2</b>	<b>7</b>
<b>STEP 3</b>	<b>7</b>
<b>STEP 4</b>	<b>7</b>
<b>STEP 5</b>	<b>7</b>
<b>STEP 6</b>	<b>8</b>
<b>STEP 7</b>	<b>8</b>
<b>STEP 8</b>	<b>8</b>
<b>STEP 9</b>	<b>8</b>
<b>STEP 10</b>	<b>8</b>
<b>STEP 11</b>	<b>9</b>
<b>STEP 12</b>	<b>9</b>
<b>STEP 13</b>	<b>9</b>
<b>STEP 14</b>	<b>10</b>
<b>STEP 15</b>	<b>10</b>
<b>STEP 16</b>	<b>10</b>
<b>FINISHED PRODUCT</b>	<b>11</b>

# ***Why Uneek***

---

## ***Australian Designed and Built***

All our products are designed and manufactured right here in Australia, allowing us to have better lead times and better quality control than companies manufacturing overseas. By supporting us you're supporting to grow the Australian economy and our brand.

## ***Uneek Styling***

We do not design our bars to look the same across the vehicle range. We fully develop our own product to individually suit each vehicle. We take time in designing from scratch and then test all our bars to comply with all relevant ADRs and Australian Standards.

## ***Lightweight Through Smart Engineering***

Having a steel bar doesn't mean you have to add more weight than is required to the front of your vehicle. Our engineering practises ensure we have the right protection, designed the right way to ensure protection is at its maximum and weights at its minimum.

## ***Proven Off Road***

We take our products out and test them right here in the heart of our country in our Australian conditions so we know our products can withstand anything you throw at them.

## ***Increased Approach Angles***

Our bars are designed to give you the best advantage while off road, with increased approach angles means you can tackle those tough and steep angles better than you could with the original setup or other alternatives.

## ***Warranty***

Uneek 4x4 back itself as Australia's leading steel bull bar manufacturer. This is why we provide you with the best steel bar warranty in Australia - 5 years.

# Important Information

---



## PLEASE READ BEFORE INSTALLATION

- When installed in accordance with these instructions, the front protection bar does not affect the operation of the vehicles SRS airbags.
- This product must be installed exactly as per these instructions using only hardware supplied.
- Take a few moments to read instructions thoroughly before beginning work.
- In the event of damage to any bar component please contact Uneek 4x4 in regards to repair/replacement of components.
- Do not use this product for any vehicle make or model other than that specified on these instructions.
- Do not remove labels from this product.
- This product and its fixings must not be modified in any way unless stated in these fitting instructions.
- The installation of this product is recommended for trained personnel.
- These instructions are correct at time of publication. Uneek 4x4 cannot be held responsible for the impact of any changes subsequently made by the vehicle manufacturer.
- During installation it is the duty of the installer to check correct operation/clearances of all components.
- Supplied tow points are designed as tow points only. Use in a recovery operation will be at operator's risk.
- Installation time: 4-5 hours.
- Vehicle specific notes: A flip up license plate kit may be required. Optional Narva
- 90862 license plate light.



**EYE & EAR PROTECTION REQUIRED**



**DRILLING REQUIRED**



**TWO PERSON LIFT REQUIRED**



**TORQUE SETTING**



**CUTTING OR GRINDING REQUIRED**

---

### FASTENER TORQUE SETTINGS:

M6 – 9Nm (4lb ft)

M8 – 22Nm (16lb ft)

M10 – 44Nm (32lb ft)

M12 – 77Nm (57lb ft)

### TOOLS REQUIRED:

**BASIC TOOL KIT:** Soldering iron or electrical in-line connectors. 18mm drill bit

Male and female spade terminals.

# Components and parts

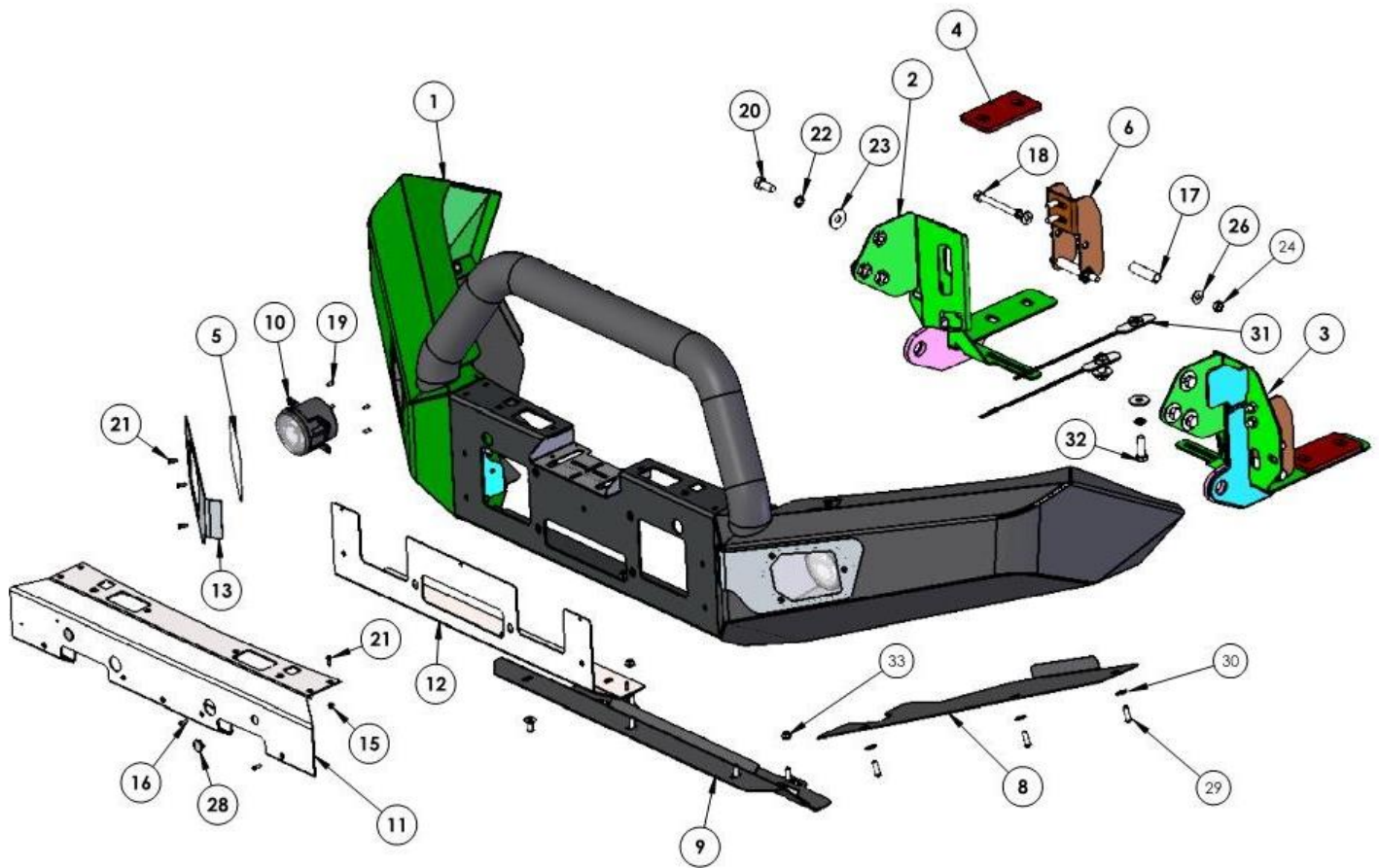

## MAIN PARTS

ITEM NO.	PART NUMBER	DESCRIPTION	QTY.
1	NN-FB-NPCE-ASM1	WELDED ASSY NISSAN NP300	1
2	03-0336R	BRACKET IMPACT ASSY NP300 CENTURY	1
3	03-0336L	IMPACT ASSY NP300	1
4	04-0242	PLATE PACKER NP300	2
5	12-0026	COVER PC FOG LIGHT CENTURY	2
6	03-0334	BRACKET CHASSIS BRACE NP300	2
7	09-0118R	PANEL OUTER NP300 CENTURY	1
8	09-0118L	PANEL OUTER NP300 CENTURY	1
9	09-0114	PANEL ASSY NP300 CENTURY	1
10	CARWAY DRL	DRL FOG LIGHT	2

# ***Components and parts***

---

## FACIA PANEL KIT

ITEM NO.	PART NUMBER	DESCRIPTION	QTY.
11	09-0124	PANELL ASSY TOP NP300	1
12	09-0126	PANEL MIDDLE CENTURY NP300	1
13	03-0338R	STAINLESS SURROUND NP300	1
14	03-0338L	STAINLESS SURROUND NP300	1

## SMALL PARTS KIT

ITEM NO.	PART NUMBER	DESCRIPTION	QTY.
15	M5 FN	M5 FLANGE NUT	13
16	M5X15 PSCREW	M5 X 15 PH SCREW	5
17	05-0162	TUBE SPACER 10NB X 65	4
18	M10x1.5X90	M10 X 1.5 X 90MM BOLT	4
19	M5X10 PSCREW	M5 X 10 PH SCREW	8
20	M12X30X1.75	BOLT M12 1.75 PITCH	6
21	M5X16 CS	M5 COUNTERSUNK SCREW	16
22	M12 SW	M12 SPRING WASHER	8
23	M12 FW X 37	M12 FLAT WASHER LARGE	8
24	M10X1.5N	M10 X 1.5 NUT	4
25	M10SW	M10 SPRING WASHER	8
26	M10FWX25	M10 FLAT WASHER X 25MM WIDE	12
27	M10X30	M10 X 1.5 X 30MM BOLT	4
28	SPFM18	Round plastic cap Kelvindale	2
29	M8X25 BHCS	M8X25 BUTTON HEAD CAP SCREW Z/P	11
30	M8 FW X 22	FLAT WASHER 8MM LARGE	11
31	04-0252	NUT PLATE ASSY M12 RECOVERY	2
32	M12X40X1.75	M12 X 40 X 1.75 BOLT	2
33	M8 FN	FLANGE NUT M8	2



## Step 1

Remove plastic panels under bumper, bumper, fog lights, grille and steel bumper support. Retain bolts from bumper support. Remove front bash plate. Remove the factory towpoint and retain bolts.



## Step 2

Remove plastic bumper mounts from outer guards and below headlights.

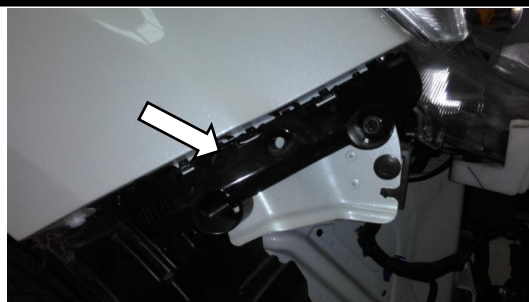

## Step 3

Remove steel mounting brackets and plastic outer air dams.

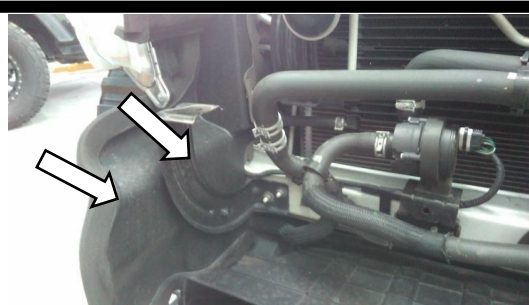

## Step 4

Fit supplied fog lights to bar using M5 x 10 Phillips head screws. If the vehicle does not have factory fog lights install the supplied wiring loom.

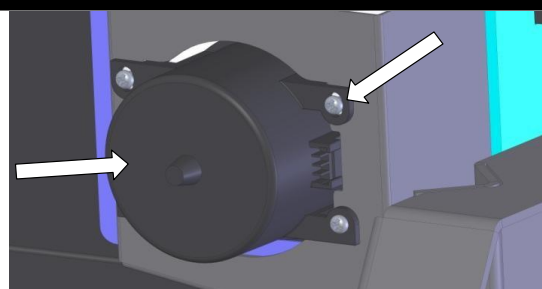

## Step 5

Install optional winch light and route cable to either side of bar. Run cable through access (arrow) hole.

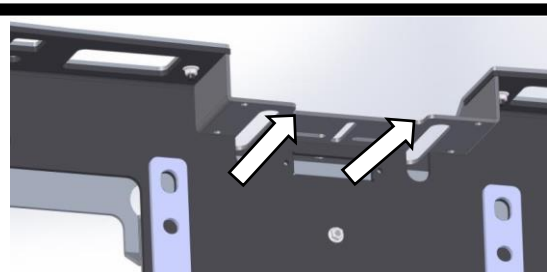

## Step 6

Fit lower stainless panel to bar using 4 x M5 countersunk screws and M5 flange nuts.

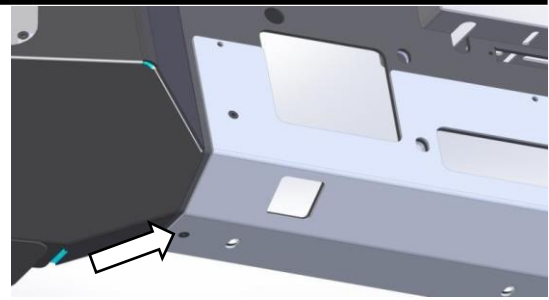

## Step 7

Fit upper panel assembly using 6 x M5 countersunk screws and flange nuts and 3 x M5 x15 Phillips head screws through the front face of panel with flange nuts.

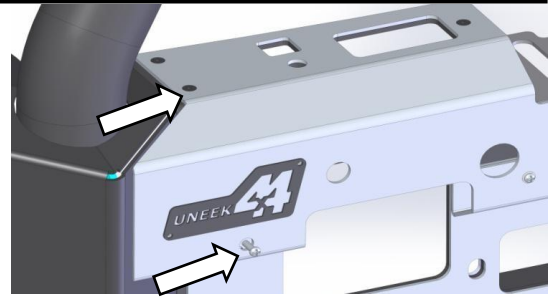

## Step 8

Fit clear cover and stainless surround using 3 x M5 countersink screws for each light. The folded section sits between the stainless center and wing of bar.

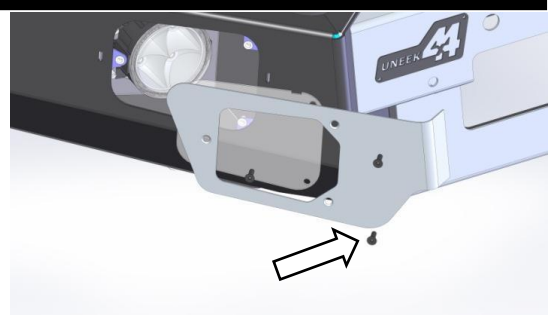

## Step 9

On light colored bars it is recommended to paint these areas satin black.



## Step 10

Drill outer chassis holes only to 18mm. De burr and paint.

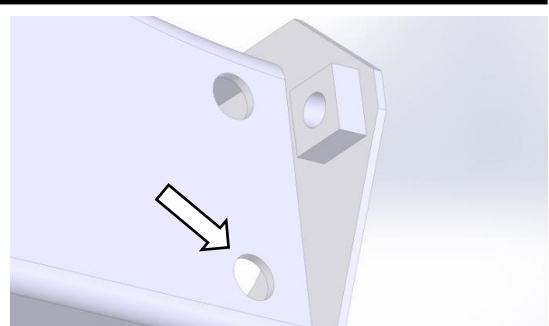



## Step 11

Fit the winch to bar making sure the clutch handle is facing forward with the winch mounting points. Fit control box to recess in bar. Before fitting bar it is recommended to paint surfaces below the lights etc satin black.

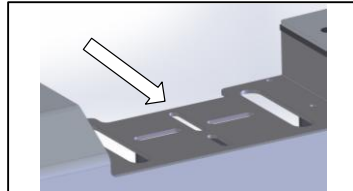

## Step 12

Loosely bolt impact absorbers to chassis face using original bolts from steel crash beam. Slide chassis packers between chassis and lower section of mount. On LH side refit using original bolts. On RH side slide M12 nut plates into chassis and secure using M12 x 40 bolts, spring washers and fat washers. Do not tighten yet.

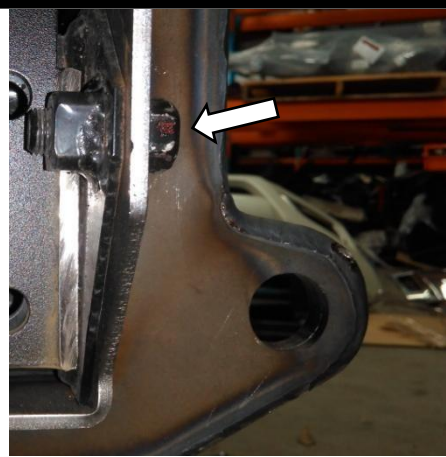

## Step 13

Slide carefully the crush tubes into the chassis rail and slide over the chassis brace onto chassis. Secure through chassis using M10 x 70 bolts, spring washers, fat washers and M10 nuts. Secure to impact absorber using M10 x 30 bolts, spring washers and fat washers. Tighten all chassis mount bolts now.

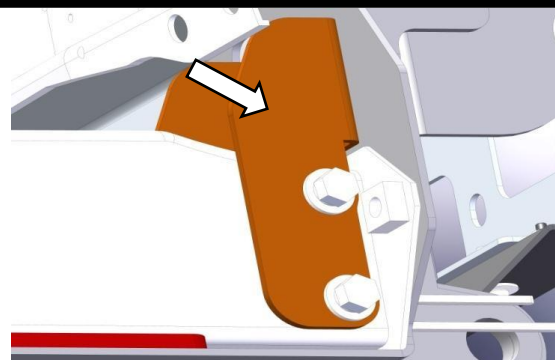

M10-44Nm M12-77Nm

## Step 14

With the help of another person lift bar onto vehicle and secure using M12 x 30 bolts, spring washers and large fat washers. Make sure area shown by arrow has a minimum 15mm gap.



M12-77Nm

## Step 15

Complete all wiring before fitting stone guards. Fit middle stone guard to bar ONLY using M8 button head cap screws and fat washers. Fit original bash plate to vehicle using REAR holes only. Secure middle panel through original bash plate and into slotted hole on chassis bracket using M8 cap screws, fat washers and M8 flange nuts. The large square hole allows access to flange nut. Tighten when done.



M8-22Nm

## Step 16

Loosely fit outer panels using M8 button head cap screws and fat washers and mark a line on the plastic inner guards. Remove panel and cut plastic and de burr. Re-fit panel and tighten. Place plastic guard over the lip of the outer panel. Clean bar.



M8-22Nm

# ***Finished Product***

---



Revised: 07/08/2019

***Australia's Best  
Off Road Products  
Created... Not Cloned***

20 Gateway Drive, Carrum Downs, VIC, 3201

1800 806 952

[www.uneek4x4.com.au](http://www.uneek4x4.com.au)

