

UNEK44
AUSTRALIA
OFF ROAD ACCESSORIES

SKU: TL-RB-76-ASM0



Fitting Instructions

***Toyota LC 76 Series 2007 on
Rear Bar***

***Australia's Best Off Road Products
Created... Not Cloned***

Contents

WHY UNEEK	4
IMPORTANT INFORMATION	5
COMPONENTS AND PARTS	6
STEP 1	9
STEP 2	9
STEP 3	9
STEP 4	9
STEP 5	9
STEP 6	10
STEP 7	10
STEP 8	10
STEP 9	10
STEP 10	11
STEP 11	11
STEP 12	11
STEP 13	11
STEP 14	12
STEP 15	12

STEP 16	12
STEP 17	13
STEP 18	13
STEP 19	13
STEP 20	14
STEP 21	14
FINISHED PRODUCT	15

Why Uneek

Australian Designed and Built

All our products are designed and manufactured right here in Australia, allowing us to have better lead times and better quality control than companies manufacturing overseas. By supporting us you're supporting to grow the Australian economy and our brand.

Uneek Styling

We do not design our bars to look the same across the vehicle range. We fully develop our own product to individually suit each vehicle. We take time in designing from scratch and then test all our bars to comply with all relevant ADRs and Australian Standards.

Lightweight Through Smart Engineering

Having a steel bar doesn't mean you have to add more weight than is required to the front of your vehicle. Our engineering practises ensure we have the right protection, designed the right way to ensure protection is at its maximum and weights at its minimum.

Proven Off Road

We take our products out and test them right here in the heart of our country in our Australian conditions so we know our products can withstand anything you throw at them.

Increased Approach Angles

Our bars are designed to give you the best advantage while off road, with increased approach angles means you can tackle those tough and steep angles better than you could with the original setup or other alternatives.

Warranty

Uneek 4x4 back itself as Australia's leading steel bull bar manufacturer. This is why we provide you with the best steel bar warranty in Australia - 5 years.

Important Information



PLEASE READ BEFORE INSTALLATION.

- This product must be installed exactly as per these instructions using only hardware supplied.
- Take a few moments to read instructions thoroughly before beginning work.
- In the event of damage to any bar component please contact Uneek 4x4 in regards to repair/replacement of components.
- Do not use this product for any vehicle make or model other than that specified on these instructions.
- This product and its fixings must not be modified in any way unless stated in these fitting instructions.
- The installation of this product is recommended for trained personnel.
- These instructions are correct at time of publication. Uneek 4x4 cannot be held responsible for the impact of any changes subsequently made by the vehicle manufacturer.
- During installation it is the duty of the installer to check correct operation/clearances of all components.
- Installation time: 6 hours
- Optional right hand and left-hand swing outs are available to carry tyres, or jerry cans.
- This tyre carrier is designed to carry the weight and size of a 35" tyre, carry larger tyres at your own risk, or two 33" tyres
- Always maintain the utmost care when using a hi-lift jack on any vehicle



EYE & EAR PROTECTION REQUIRED



DRILLING REQUIRED



TWO PERSON LIFT REQUIRED



TORQUE SETTING



CUTTING OR GRINDING REQUIRED

FASTENER TORQUE SETTINGS:

M6 – 9Nm (4lb ft)

M8 – 22Nm (16lb ft)

M10 – 44Nm (32lb ft)

M12 – 77Nm (57lb ft)

TOOLS REQUIRED:

Basic tool kit with sockets, spanners and hex keys, power drill and 12mm drill bit.

General purpose grease, rubber mallet, soldering iron with solder, wire and spade terminals.

Components and parts

Rear Bumper

ITEM NO.	PART NUMBER	DESCRIPTION	QTY.
1	TL-RB-76-ASM1	TOYOTA 76 REAR BAR WELDED ASSY	1
2	04-0182	PLATE PACKER 76 REAR BAR	4
3	SQUARE LED REAR LIGHT	SQUARE LED TAIL LIGHT	2
4	04-0075	PLATE PIN SLIDE	1
5	M6X16 BHCS	M6 BUTTON HEAD CAP SCREW	6
6	M6 FN	FLANGE NUT M6	6
7	M12 SW	M12 SPRING WASHER	2
8	M12 FW	M12 FLAT WASHER	2
9	09-0120	PANEL CENTER 76 REAR BAR	1
10	04-0258	PLATE ASSY NUT 76 REAR	2
11	U4X4-LOGO PLATE- 1	LOGO PLATE-1	1
12	CARWAY DRL	DRL FOG LIGHT	2
13	M12X40X1.25	M12 X 40 X 1.25 BOLT	2
14	M5 NUTSERT	NUTSERT 5MM	14
15	M5X10 PSCREW	M5 X 10 PH SCREW	8
16	M5X15 PSCREW	M5 X 15 PH SCREW	2
17	M14 x 50 x 1.5	M14X50 FINE THREAD ZP 8.8	6

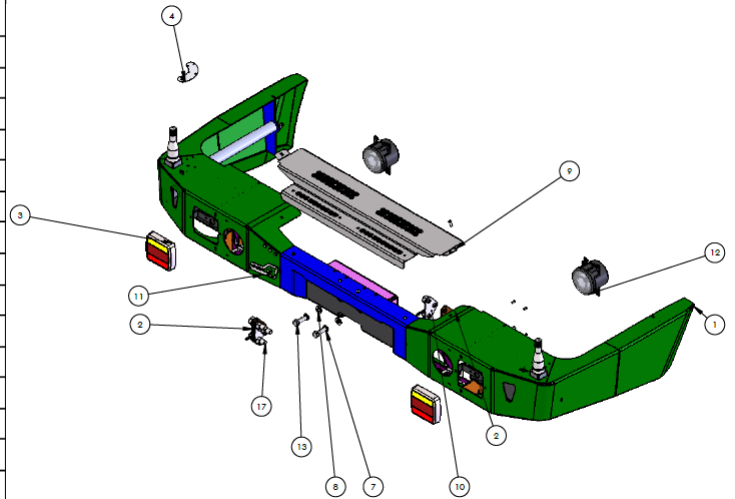

Right Hand Swing Away

ITEM NO.	PART NUMBER	DESCRIPTION	QTY.
1	JK-RB-TC-23	TIE ROD ADJUSTER	1
2	JK-RB-23	SOFT STOP	1
3	M12 Rod end LH	Rod end LH M12	1
4	03-0090	BRACKET ASSY TYRE MOUNT	1
5	M10 X 30 BOLT	M10 X 30 HEX ZP 8.8	6
6	M10FWX25	M10 FLAT WASHER X 25MM WIDE	12
7	M10SW	M10 SPRING WASHER	6
8	M10X1.5N	M10 X 1.5 NUT	6
9	M12X30	M12 X 30 HEX HT	2
10	M12 SW	M12 SPRING WASHER	2
11	M12 FW	M12 FLAT WASHER	8
12	M12 Rod end RH	Rod end RH M12	1
13	M12 JAM NUT RH	M12 JAM NUT	1
14	M12 JAM NUT LH	M12 JAM NUT REVERSE THREAD	1
15	M12-1.75 x 50	M12x50-8.8 HEX BOLT Z/P	2
16	M12 NYLOC	M12 Nyloc	2
17	M8 NYLOC	M8 Nyloc	2
18	M8 FW X 22	FLAT WASHER 8MM LARGE	2
19	HUB BEARING	BEARING ARM HUB	2
20	HUB CAP	HUB CAP AND SPLIT PIN	1
21	CASTLE NUT	CASTLE NUT	1
22	M12x 1.25 wheel nut	M12 x 1.25 Wheel nut	3
23	GU-RB-ASM2	GU patrol tyre carrier	1
24	03-0340	BRACKET ARM REST 76 REAR	1
25	TL-RB-TM-ASM1	TYRE MOUNT 76	1
26	M8 X 30	M8 X 30 HEX BOLT 8.8 Z/P	2

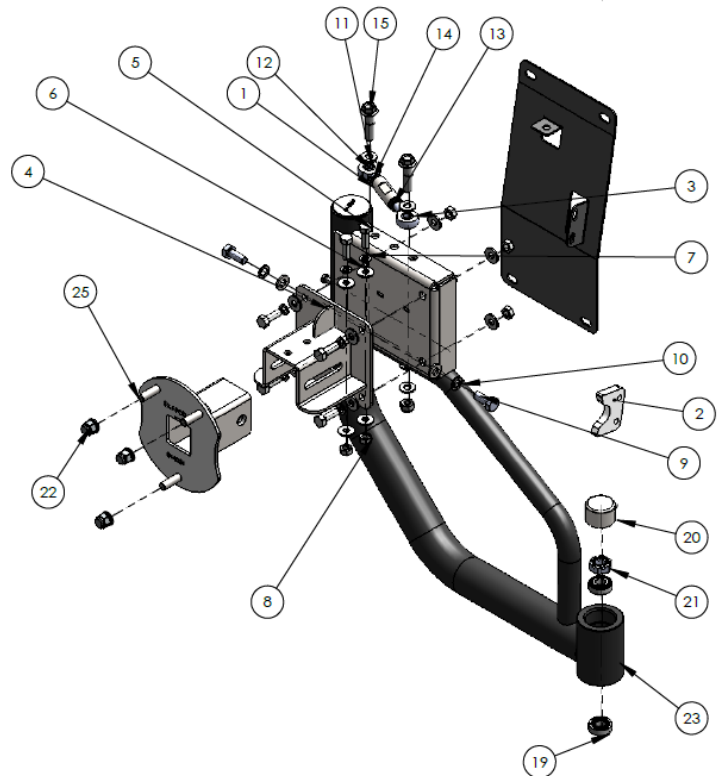

Components and parts

Left Hand Swing Away Lower Version

ITEM NO.	PART NUMBER	DESCRIPTION	QTY.
1	41010	DEE BEE SMALL	1
2	1-400-R	EBERHARD SLAM LATCH RH	1
3	2T-400-52	Eberhard striker pin	1
4	03-0050	actuator	1
5	HUB CAP	HUB CAP AND SPLIT PIN	1
6	TRAILER BEARINGS	TRAILER BEARINGS	2
7	M8 FLANGE NUT	M8 FLANGE NUT	4
8	M5X15 PSCREW	M5 X 15 PH SCREW	2
9	m5 washer	M5 washer	2
10	M5 NYLOCK NUT	M5 NYLOCK NUT	3
11	M10 NYLOC	NYLOC SELF LOCKING NUT	1
12	Extension Spring	extension spring	1
13	M6X25 BHCS	M6X25 BUTTON HEAD CAP SCREW S/S	1
14	M6 FLAT WASHER	M6 FLAT WASHER	2
15	M6 FN	FLANGE NUT M6	1
16	03-0090	BRACKET ASSY TYRE MOUNT	1
17	M12x 1.25 wheel nut	M12 x 1.25 Wheel nut	3
18	M10 X 30 BOLT	M10 X 30 HEX ZP 8.8	6
19	M10FWX25	M10 FLAT WASHER X 25MM WIDE	12
20	M12X30	M12 X 30 HEX HT	2
21	M12 FW	M12 FLAT WASHER	2
22	M12 SW	M12 SPRING WASHER	2
23	M10SW	M10 SPRING WASHER	6
24	M10X1.5N	M10 X 1.5 NUT	6
25	M8 FLAT WASHER	M8 FLAT WASHER	4
26	TL-RB-ARMLH-ASM1	76 LH REAR ARM	1
27	03-0360	BRACKET COVER 76 REAR	1
28	CASTLE NUT	CASTLE NUT	1
29	M8X25 BHCS	M8X25 BUTTON HEAD CAP SCREW Z/P	4
30	TL-RB-TM-ASM1	TYRE MOUNT 76	1
31	03-0342	BRACKET LATCH PIN 76	1
32	M8 X 30	M8 X 30 HEX BOLT 8.8 Z/P	3
33	M8 SW	M8 SPRING WASHER	3
34	M8 WASHER	M8 WASHER	3
35	M6 x 30 HEX BOLT Z/P	M6 X 30 HEX BOLT Z/P	3
36	m6 washer	m6 washer	3
37	M6 NYLOCK NUT	M6 NYLOCK NUT	3

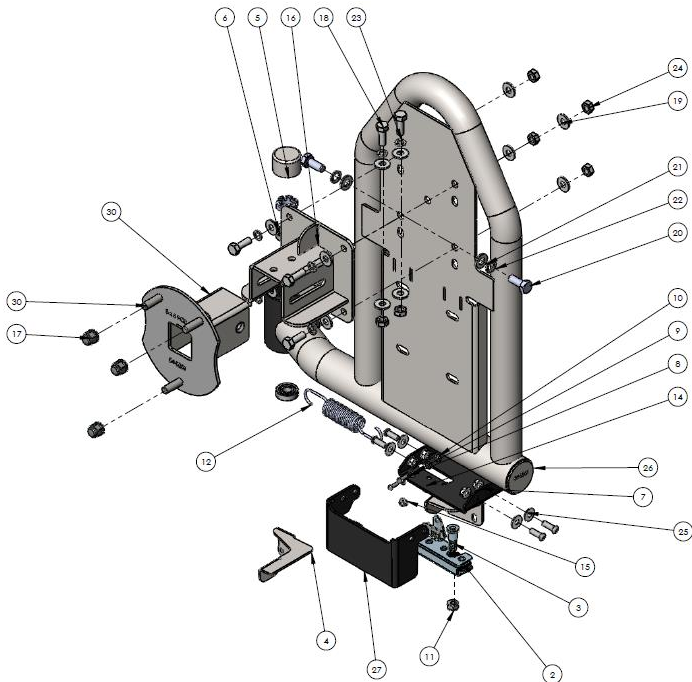

Jerry Can Holder Suit Lower Version

ITEM NO.	PART NUMBER	DESCRIPTION	QTY.
1	TL-RB-ARMLH-ASM1	76 LH REAR ARM	1
2	41010	DEE BEE SMALL	1
3	03-0360	BRACKET COVER 76 REAR	1
4	1-400-R	EBERHARD SLAM LATCH RH	1
5	2T-400-52	Eberhard striker pin	1
6	HUB CAP	HUB CAP AND SPLIT PIN	1
7	TRAILER BEARINGS	TRAILER BEARINGS	2
8	CASTLE NUT	CASTLE NUT	1
9	M8X25 BHCS	M8X25 BUTTON HEAD CAP SCREW Z/P	4
10	M8 FLANGE NUT	M8 FLANGE NUT	4
11	M8 FLAT WASHER	M8 FLAT WASHER	4
12	M5X15 PSCREW	M5 X 15 PH SCREW	2
13	m5 washer	M5 washer	2
14	M5 NYLOCK NUT	M5 NYLOCK NUT	3
15	M10 NYLOC	NYLOC SELF LOCKING NUT	1
16	Extension Spring	extension spring	1
17	M6X25 BHCS	M6X25 BUTTON HEAD CAP SCREW S/S	1
18	M6 FLAT WASHER	M6 FLAT WASHER	2
19	M6 FN	FLANGE NUT M6	1
20	03-0050	actuator	1
21	M10 X 30 BOLT	M10 X 30 HEX ZP 8.8	4
22	M10FWX25	M10 FLAT WASHER X 25MM WIDE	8
23	M10SW	M10 SPRING WASHER	4
24	M10X1.5N	M10 X 1.5 NUT	4
25	03-0342	BRACKET LATCH PIN 76	1
26	M8 SW	M8 SPRING WASHER	3
27	M8 WASHER	M8 WASHER	3
28	JC-RB-ASM1	Jerry can mount asm	1
29	M8 X 30	M8 X 30 HEX BOLT 8.8 Z/P	3
30	M6 NYLOCK NUT	M6 NYLOCK NUT	3
31	M6 x 30 HEX BOLT Z/P	M6 X 30 HEX BOLT Z/P	3
32	m6 washer	m6 washer	3

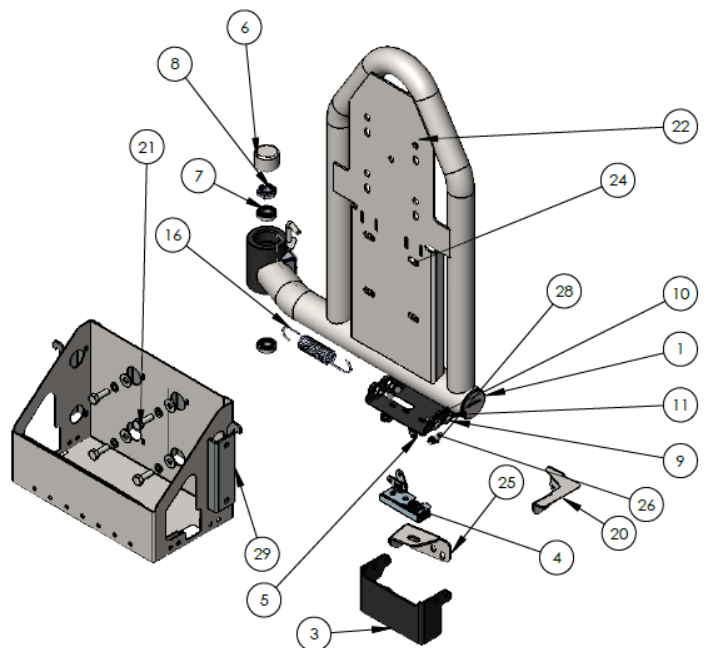

Components and parts

Left Hand Dual Jerry Can Holder

ITEM NO.	PART NUMBER	DESCRIPTION	QTY.
1	TL-RB-ARMLH-ASM1	76 LH REAR ARM	1
2	41010	DEE BEE SMALL	1
3	03-0360	BRACKET COVER 76 REAR	1
4	1-400-R	EBERHARD SLAM LATCH RH	1
5	2T-400-52	Eberhard striker pin	1
6	HUB CAP	HUB CAP AND SPLIT PIN	1
7	TRAILER BEARINGS	TRAILER BEARINGS	2
8	CASTLE NUT	CASTLE NUT	1
9	M8X25 BHCS	M8X25 BUTTON HEAD CAP SCREW Z/P	4
10	M8 FLANGE NUT	M8 FLANGE NUT	4
11	M8 FLAT WASHER	M8 FLAT WASHER	4
12	M5X15 PSCREW	M5 X 15 PH SCREW	2
13	m5 washer	M5 washer	2
14	M5 NYLOCK NUT	M5 NYLOCK NUT	3
15	M10 NYLOC	NYLOC SELF LOCKING NUT	1
16	Extension Spring	extension spring	1
17	M6X25 BHCS	M6X25 BUTTON HEAD CAP SCREW S/S	1
18	M6 FLAT WASHER	M6 FLAT WASHER	2
19	M6 FN	FLANGE NUT M6	1
20	03-0050	actuator	1
21	M10 X 30 BOLT	M10 X 30 HEX ZP 8.8	10
22	M10FWX25	M10 FLAT WASHER X 25MM WIDE	14
23	M10SW	M10 SPRING WASHER	10
24	M10X1.5N	M10 X 1.5 NUT	10
25	03-0342	BRACKET LATCH PIN 76	1
26	M8 X 30	M8 X 30 HEX BOLT 8.8 Z/P	3
27	M8 SW	M8 SPRING WASHER	3
28	M8 WASHER	M8 WASHER	3
29	JC-RB-ASM1	Jerry can mount asm	2
30	03-0623	jerry can double converter plate	1
31	M6 NYLOCK NUT	M6 NYLOCK NUT	3
32	M6 x 30 HEX BOLT Z/P	M6 X 30 HEX BOLT Z/P	3
33	m6 washer	m6 washer	3

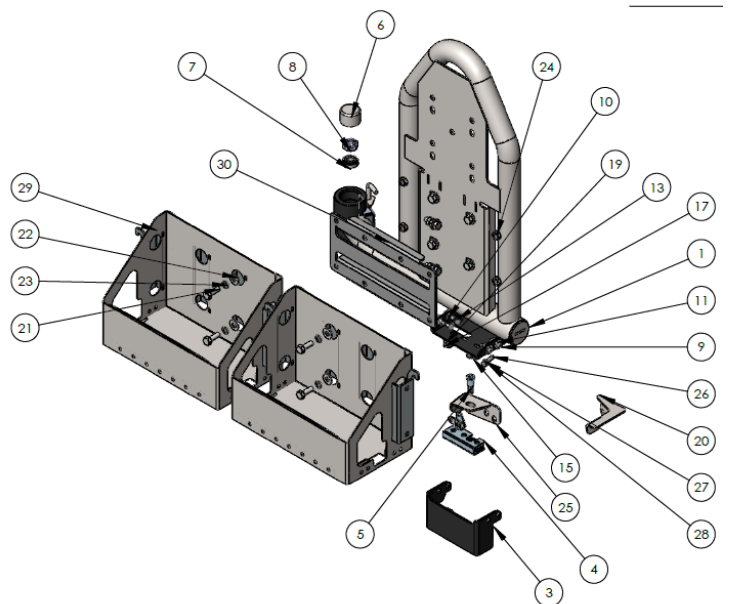

Step 1

Remove factory bumper and spare tyre including factory tyre carrier.



Step 2

First thing to do is wire up all the lights. You can tap into the tow bar wiring loom or the factory rear lights. Use the reverse circuit for both rear reverse lights as trigger. Use spade terminals so the bumper can one day be removed. Correct wires are listed on the package.



Step 3

Wires shown hanging down ready to plug into lights once installed in the bumper. If you are not fitting a LH swing away arm then leave the number plate where it is, otherwise wire in the supplied number plate light to the centre section of the bar.

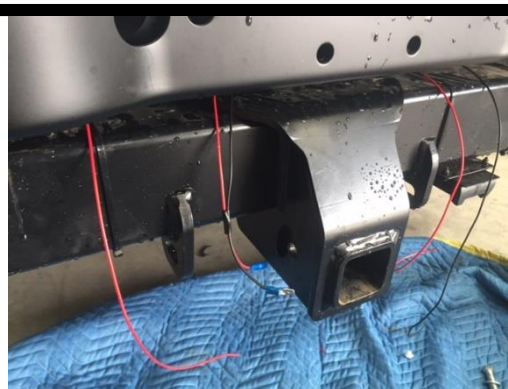

Step 4

Mount reverse lights with M5 hardware. Ensure correct spade terminals are fitted to match wires from vehicle you just tapped into.



Step 5

Mount Indicator/stop lamp as shown with supplied hardware.



Step 6

Fit Step with M6 button head cap screws and nuts.



Step 7

Fit Nut plate inside chassis and secure with one M14 bolt like shown, leave loose.



Step 8

Fit new bumper onto chassis with the help of a friend, fasten two M12x40 fine thread bolts located in rear just below step.

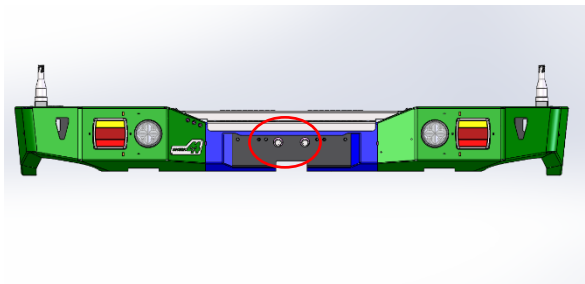

Step 9

Use M14 bolts provided to secure. Torque up bolts.



Step 10

Fit door bracket with factory hardware.



Step 11

Fit RH swing arm. Put seal on stub axle, then large bearing. Lift on the arm then put on small bearing followed by large washer then secure down with castle nut. Tension up nut quite tight to preload the bearing. Fit cap on top with a mallet.



Step 12

Fit plastic soft stop with M8 hardware as shown.



Step 13

Fit tie rod with M12 hardware and torque fasteners. Use this to tension the swing arm. With the door closed adjust rod ends so arm is sitting inside the cradle of the soft stop. Pull against the tyre carrier and if play is felt open the door and reduce the length of the tie rod until you feel no play with the door closed.



Note: over time as the stop wears you will need to re-tension the tie rod.

Step 14

Fit tyre mount with M10 hardware on to swing arm, and M12 bolts on side.



Step 15

You next need to put the tyre on the carrier and push the tyre back as far as it can go. The idea is for the bottom of the tyre to rest against the tyre carrier itself. Mark this position on the top of the tyre mount as shown with the arrow to the right. Then move your mark 5mm further back towards the car to ensure the tyre is forced hard on to the tyre carrier when installed. Drill out these holes with 12mm drill and fit M10x30 bolts with spring washer's flat washers and nuts. Torque all bolts.

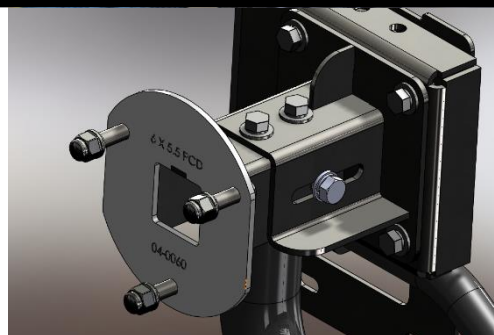

Step 16

Put a small cut on the factory flares as shown and refit.



Step 17

Next step is for the optional LH swing away. If installing a LH tyre mount do the same as the Right hand in regard to the tyre and mounting the arm, then mount the slam latch as shown, with M6 hardware. Also mount the rubber stopper and latch cover as well as latch actuation lever.

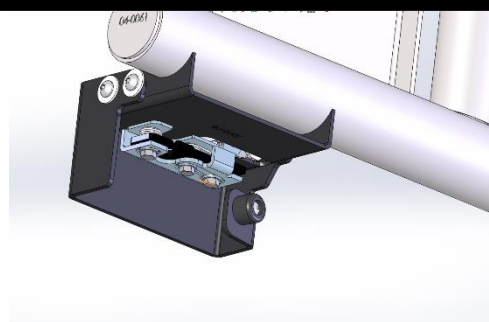

Step 18

Mount the striker pin and mount as shown. Now you will need to adjust the latch and the pin so that the whole swing arm opens and closes nicely. You may also need to shim the rubber stopper closer to the bar for a proper latch.

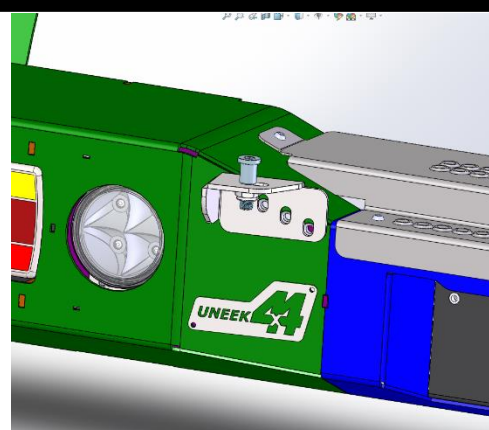

Step 19

If mounting a single Jerry can holder, simply insert the hooks on the back of the holder on to the swing arm which will support its' weight and secure with M10 hardware. Torque bolts.

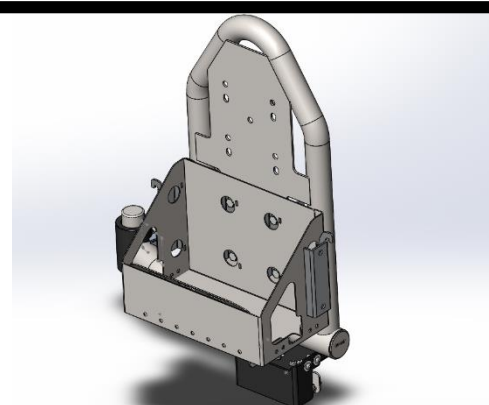

Step 20

If fitting dual jerry can holder you will need converter plate to mount the jerry cans like shown. Use M10 hardware to secure. Otherwise you can turn the Jerry can mounts 90 degrees and mount them back to back and still hook onto the swing arm

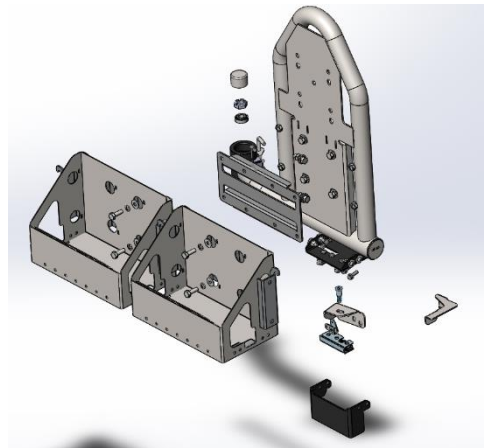

Step 21

You have now completed the install. Check all clearances and swing arms work as they should, and you're finished.

Finished Product



Revised: 07/05/2020

***Australia's Best
Off Road Products
Created... Not Cloned***

20 Gateway Drive, Carrum Downs, VIC, 3201

1800 806 952

www.uneek4x4.com.au

