

UNEK44
AUSTRALIA
OFF ROAD ACCESSORIES

SKU: WK2-BP-ASM0



Fitting Instructions

Jeep WK2 Grand Cherokee 2011-2022

Bash Plate

***Australia's Best Off Road Products
Created... Not Cloned***

Contents

WHY UNEEK	3
IMPORTANT INFORMATION	4
COMPONENTS AND PARTS	5
STEP 1	6
STEP 2	6
STEP 3	6
STEP 4	6
STEP 5	7
STEP 6	7
STEP 7	7
STEP 8	7
STEP 9	8
STEP 10	8
STEP 11	8
FINISHED PRODUCT	9

Why Uneek

Australian Designed and Built

All our products are designed and manufactured right here in Australia, allowing us to have better lead times and better quality control than companies manufacturing overseas. By supporting us you're supporting to grow the Australian economy and our brand.

Uneek Styling

We do not design our bars to look the same across the vehicle range. We fully develop our own product to individually suit each vehicle. We take time in designing from scratch and then test all our bars to comply with all relevant ADRs and Australian Standards.

Lightweight Through Smart Engineering

Having a steel bar doesn't mean you have to add more weight than is required to the front of your vehicle. Our engineering practises ensure we have the right protection, designed the right way to ensure protection is at its maximum and weights at its minimum.

Proven Off Road

We take our products out and test them right here in the heart of our country in our Australian conditions so we know our products can withstand anything you throw at them.

Increased Approach Angles

Our bars are designed to give you the best advantage while off road, with increased approach angles means you can tackle those tough and steep angles better than you could with the original setup or other alternatives.

Warranty

Uneek 4x4 back itself as Australia's leading steel bull bar manufacturer. This is why we provide you with the best steel bar warranty in Australia - 5 years.

Important Information



PLEASE READ BEFORE INSTALLATION.

- This product must be installed exactly as per these instructions using only hardware supplied.
- Take a few moments to read instructions thoroughly before beginning work.
- In the event of damage to any components please contact Uneek 4x4 in regards to repair/replacement of components.
- Do not use this product for any vehicle make or model other than that specified on these instructions.
- This product and its fixings must not be modified in any way unless stated in these fitting instructions.
- The installation of this product is recommended for trained personnel.
- These instructions are correct at time of publication. Uneek 4x4 cannot be held responsible for the impact of any changes subsequently made by the vehicle manufacturer.
- During installation it is the duty of the installer to check correct operation/clearances of all components.
- Installation time:1-2 hours.
- Vehicle specific notes: This bash plate will suit vehicles with aftermarket bull bars.



EYE & EAR PROTECTION REQUIRED



DRILLING REQUIRED



TWO PERSON LIFT REQUIRED



TORQUE SETTING



CUTTING OR GRINDING REQUIRED

FASTENER TORQUE SETTINGS:

M6 – 9Nm (4lb ft)

M8 – 22Nm (16lb ft)

M10 – 44Nm (32lb ft)

M12 – 77Nm (57lb ft)

TOOLS REQUIRED:

Hammer and center punch

Power drill

10.5mm drill bit

5mm drill bit

20mm hole saw or step drill

Socket set and or hand spanners

Tape measure

Marking pen or paint pen

Cable ties (x2)

Components and parts

ITEM NO.	PART NUMBER	DESCRIPTION	QTY.
1	WK2-BP-ASM1	GRAND CHERO WK2 BASH PLATE	1
2	M8 x 55 hex bolt 10.9	M8 X 55 HEX BOLT 10.9 Z/P	2
3	M8 WASHER	M8 WASHER	2
4	M8 SPRING WASHER	M8 SPRING WASHER	2
5	M10 x 90	M10 X 90 HEX BOLT Z/P	3
6	M10 HD WASHER	M10 HD WASHER Z/P	6
7	CRUSH TUBE 10NB X 50	CRUSH TUBE 10NB X 50	3
8	M10 NYLOC	NYLOC SELF LOCKING NUT	3
9	SHIPPER 930 X 440 X 110	SHIPPER 930 X 440 X 110	1

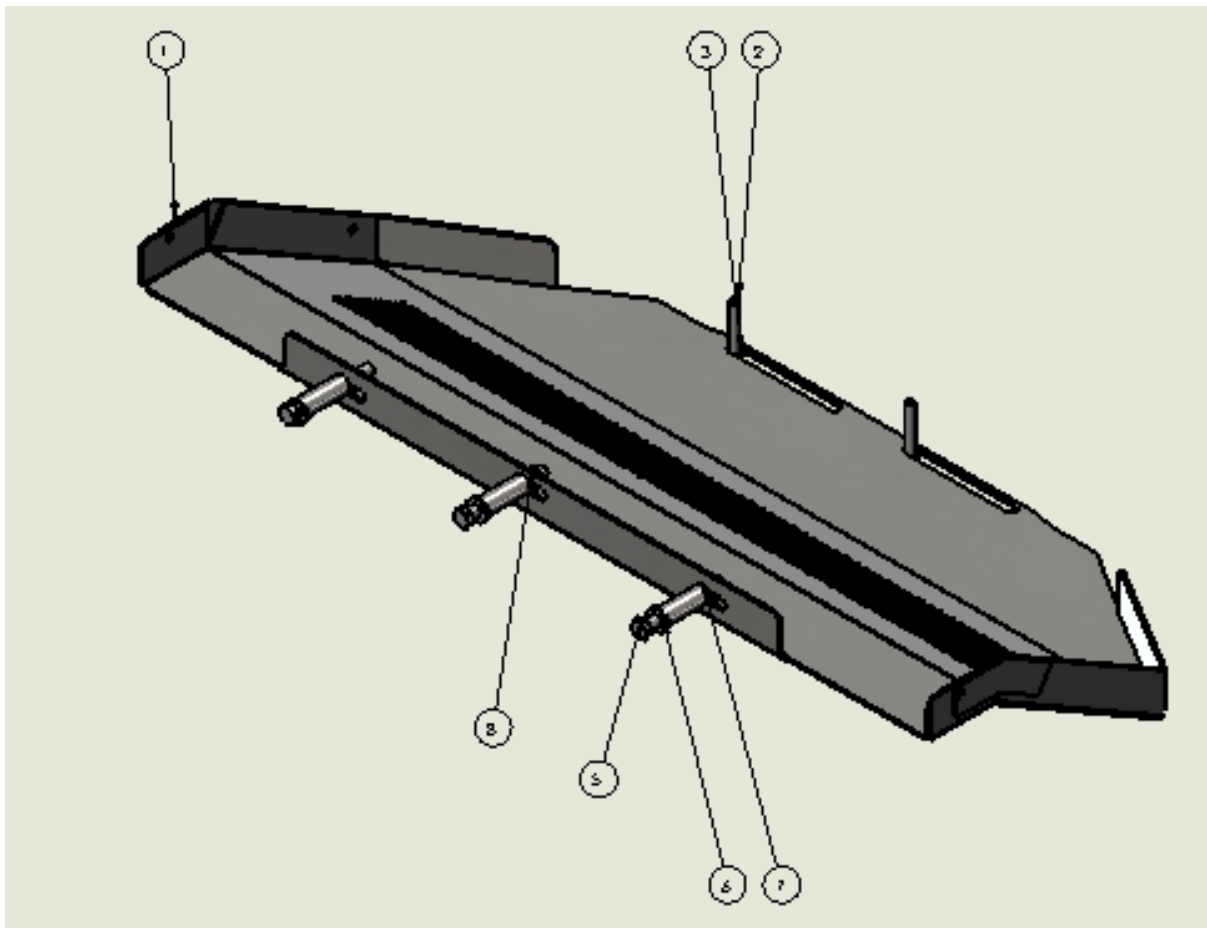

Step 1

Start off by removing 7 quarter turn plastic plugs underneath the air damn. Note 2 are up inside the air damn.



Step 2

Pull the air damn away from the bumper. Don't be scared to use a little bit of force.



Step 3

Remove under liner from vehicle.

2 bolts at the rear and 3 up front with one clip.



Step 4

Mark and center punch your holes to be drilled. One hole should be directly in the middle of the cross member and up 25mm from the lower edge. Then measure and mark out a hole 200mm either side of this central hole 25mm up. Centre punch each hole.



Step 5

Drill a small pilot hole 5mm all the way through the cross member for each hole, then step up to the hole-saw or step drill and drill only through the front edge of each hole. Do not go all the way through.

It's a good idea to use coolant when drilling with a hole saw.



Step 6

Once each 20mm hole is drilled, you can now drill all the way through the back edge with a 10.5mm drill.

Put some black paint over the drilled edges to prevent rust.



Step 7

With the transmission guard hanging down feed the bash plate into place and using M8 x 55 bolts with washers do them up a couple of turns.



Step 8

Raise the bash plate up to the cross member and fit the M10x 90 bolts by inserting the crush tube into the cross member. Use a washer on both sides.



Step 9

Torque up each bolt.

Do not over tighten M8 bolts as it will distort the bash plate.



Step 10

Using a cable tie, secure the carpet to the bash plate.



Step 11

Refit bumper air damn and you're finished.



Finished Product



Revised: 31/07/2019

***Australia's Best
Off Road Products
Created... Not Cloned***

49-75 Pacific Drive, Keysborough, VIC, 3173

1300 806 952

www.uneek4x4.com.au

