



VEHICLE MODEL: JEEP WRANGLER
PART DESCRIPTION: 50" LED light bar mounts
MODELS '07—'14



PLEASE READ BEFORE INSTALLATION.

- Take a few moments to read instructions thoroughly before beginning work.
- In the event of damage to any component please contact Uneek 4x4 in regards to repair/replacement of components.
- These instructions are correct at time of publication. Uneek 4x4 cannot be held responsible for the impact of any changes subsequently made by the vehicle manufacturer.
- During installation it is the duty of the installer to check correct operation/clearances of all components.
- These mounts suit 50" light bars (single and double row) with end mounts like Rigid Industries, Aurora, and Hanma
- If you experience a whistle from your light bar it's recommended to flip the light bar upside down (fins facing up) or fit 6mm irrigation tubing inside the fins to prevent them flexing which causes a whistle.
- Installation time: 25 MIN



COMPONENT VIEW AND PARTS LIST

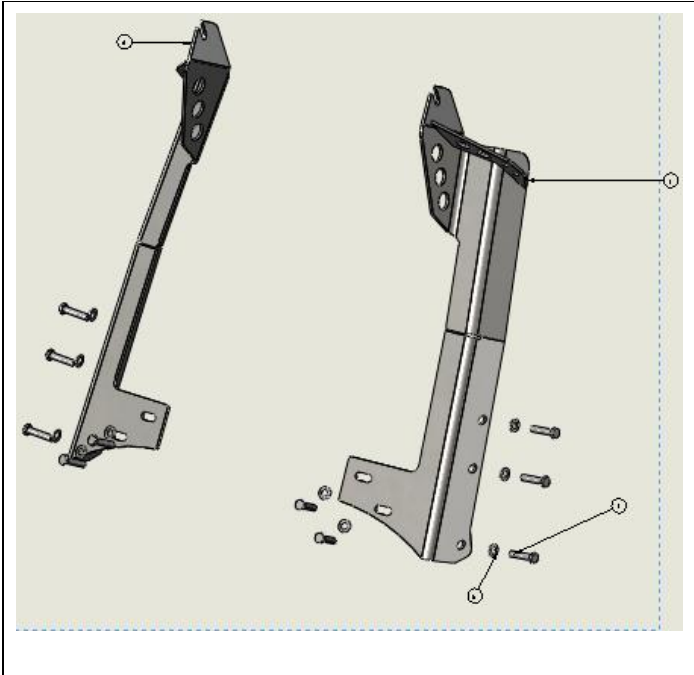

ITEM NO.	PART NUMBER	Description	QTY.
1	JK-50-LBM-ASM1L	LH 50IN LIGHT BAR MOUNT	1
2	JK-RR-30	NEOPRENE BACKING LH	1
3	JK-RR-30R	NEOPRENE CUT OUT	1
4	M8 X 35 SS	M8 X 35 HEX BOLT SS	10
5	M8 WASHER SS	M8 WASHER SS	10
6	JK-50-LBM-ASM1R	RH 50IN LIGHT BAR MOUNT	1
7	Shipper 600 x 300 x 150	Carton 600 x 300 x 150	1

FASTENER TORQUE SETTINGS:
M8 – 22Nm (16lb ft)

TOOLS REQUIRED: Basic tool kit and torx driver



1. Remove all A pillar bolts except bottom one on each side (10) using a Torx driver



2. Position LH mount over A pillar and insert M8 bolts with washers. You can reuse the factory torx bolts if you wish.
Do not torque up bolts until all bolts have at least been started by hand. Once all bolts have been started, torque each bolt, then repeat for other side.





3. If fitting with a snorkel, simply place the snorkel brackets over the top of the new light mounts.



4. Fit your light bar to the brackets as shown. We suggest flipping the bar upside down (fins up) to prevent any whistle.

If you still experience a whistle with your light bar we advise cutting some 6mm irrigation hose in 3-4" long sections and placing them throughout the length of the light bar.





5. Wire in your light bar and you're done.



Contact details and warranty information are located on Uneek 4x4's website

Web: www.uneek4x4.com.au

email: sales@uneek4x4.com.au

phone: 1300 80 69 52